



HomePlug Standards for Worldwide Multimedia In- Home Networking and BPL Access

Intellon Corporation
The World Leader in Powerline
Communications

Intellon - Company Overview

- Fabless semiconductor company
- Over 15 years of experience focused on PLC
 - Now leveraging PLC expertise to coax and twisted pair
- Two IC product lines
 - HomePlug® – main revenue driver
 - SSC – legacy line for command and control, trucking
- Over 14M total PLC ICs sold on 6 continents
 - Including over 7M HomePlug ICs
- 100+ employees
- Headquarters in Ocala, Florida
 - Other offices in San Jose and Toronto
- Privately-held

Markets

- The demand for home connectivity is exploding
 - Led by the need for simple, reliable solutions for moving content around the digital home
- Our markets are global, broad and deep
 - Strong market positions in Asia, Europe and North America
 - Broad customer base
 - Multiple market channels
 - No significant geographic or customer concentrations
- Our primary market drivers are service providers, PC/CE convergence in the digital home, and broadband over powerline (BPL)

Intellon Market Drivers

- Service providers: Cable, Telco, Sat, Wi-Max
 - Data networking, wireless extension, IPTV, VoD, new applications
 - Increased self installs, faster professional installs, wireless remediation
 - Already in volume sales to over 30 service providers worldwide
- PC/CE convergence in the Digital Home
 - Application-specific extension cords for products with ETH ports
 - Plug and Connect simplicity for embedded products
 - Reliable, easy connectivity helps retailers sell other products
 - Outlet ubiquity and powerline/coax hybrid systems allow easy cross over between PC and CE ecosystems
- Broadband over Powerline
 - Internet access to the home (last mile PLC)
 - Smart grid management – whole new approach to the business model
- Command and Control

The Market Opportunity

- Content and convergence are driving the Digital Home
- Simple, reliable connectivity is essential to content delivery
- Wireless alone is not enough, especially for entertainment
 - Range limitations
 - Security concerns
 - Unable to meet consumer expectations for reliable video delivery
 - Difficult for most consumers to set up for AV content delivery
 - Why use valuable Wi-Fi bandwidth for fixed devices?
- Wireline solutions are also required
- HomePlug® powerline communications provides the best wireline solution for connecting the Digital Home

HomePlug Advantages

- Simple and reliable
 - Easy to set up and use; very low return rates and service calls
 - Proven globally by service providers and consumers
- Only technology that meets requirements for AV CE applications and PC/CE convergence
 - Reliable bandwidth with whole house coverage and robust QoS
 - Maximum ubiquity: High number of convenient outlets, no new wiring
- Useful in primary and hybrid network applications
 - Dual networks: Powerline for fixed devices; wireless for mobility
 - Backbone network for WiFi and UWB
 - Single MAC/PHY solution for PLC, Coax and Twisted Pair
- Consumer/retail-friendly (unlike coax-only solutions)

Intellon Market Drivers

- Service providers: Cable, Telco, Sat, Wi-Max
 - Data networking, wireless extension, IPTV, VoD, new applications
 - Increased self installs, faster professional installs, wireless remediation
 - Already in volume sales to over 30 service providers worldwide
- PC/CE convergence in the Digital Home
 - Application-specific extension cords for products with ETH ports
 - Plug and Connect simplicity for embedded products
 - Reliable, easy connectivity helps retailers sell other products
 - Outlet ubiquity and powerline/coax hybrid systems allow easy cross over between PC and CE ecosystems
- Broadband over Powerline
 - Internet access
 - Smart grid management – whole new approach to the business model
 - Cost benefits from single silicon solution for smart grid, access and in-home

Intellon's Competitive Advantages

- Technology Leadership
 - Invented and patented baseline technology for 3 industry standards, including HomePlug 1.0
 - Major contributor to baseline technology for HomePlug AV standard
 - Single MAC/PHY solution for PLC, Coax and Twisted Pair
- Production and Sales Leadership
 - Shipped over 14 million PL ICs
 - World leader in HomePlug IC sales with over 8 million sold on six continents
 - Volume sales to BPL, cable, Telco, satellite and WiMAX providers
- Customer Enablement Experience
 - Industry leader in enabling powerline communications in consumer products
- Powerline Knowledge
 - More real world PL experience than anyone

Top Tier Global Customer Base





Top Tier Global Customer Base

A collection of logos for various technology companies, arranged in a grid. The logos include:

- AirLink COMMUNICATIONS
- Asoka USA
- ASUS
- Aztech TOTAL POWER PERFORMANCE
- BELKIN.
- BeWAN systems
- 4Line
- CAMEO
- CURRENT TECHNOLOGIES
- SAGEM
- devolo
- dish NETWORK
- GigaFast
- LEA
- MOTOROLA
- NETGEAR
- PHILIPS
- RCA
- RadioShack.
- SMC Networks
- SHARP
- sling MEDIA
- Solwise Now in our 15th year
- SUMITOMO ELECTRIC
- Telkonet
- THOMSON images & beyond
- ubicod
- wilife
- ZyXEL
- Packard Bell.
- LINKSYS A Division of Cisco Systems, Inc.
- D-Link Building Networks for People
- BEKO
- Actiontec
- HOMEPLUG POWERLINE ALLIANCE

Intellon-Enabled Service Providers



HomePlug Ecosystem

- HomePlug is the global leader in PLC standards
- Major industry players are backing HomePlug
- Over 70 members worldwide and growing fast
- PLC standards, with complete global ecosystem, multiple IC providers and strong compliance testing

HomePlug Alliance Sponsor/Board Members

 Comcast.



MOTOROLA



SONY.

 **EarthLink**



LINKSYS[®]
A Division of Cisco Systems, Inc.

 **RadioShack**

SHARP.

TCL

 **TEXAS
INSTRUMENTS**



Intellon Product Overview

Intellon HomePlug Product Family

Three levels of Price/Performance tailored to the needs of consumer product applications:

Data

INT 5200

HomePlug 1.0
14 Mbps PHY

SD Video Fat Pipe Data

INT 5500

INT5500
HomePlug 1.0
with Turbo
85 Mbps PHY

HD Video/Audio

INT 6000

INT6000
HomePlug AV
200 Mbps
PHY



INT5200 – HomePlug 1.0

Features

- Single-chip powerline networking transceiver with integrated MII, Ethernet and USB interfaces
- Integrated ADC, DAC, AGC, filters and power amplifier
- HomePlug 1.0 compliant
- Up to 14 Mbps data rate on the powerline
- Orthogonal Frequency Division Multiplexing (OFDM) with patented signal processing techniques for high data reliability in noisy media conditions

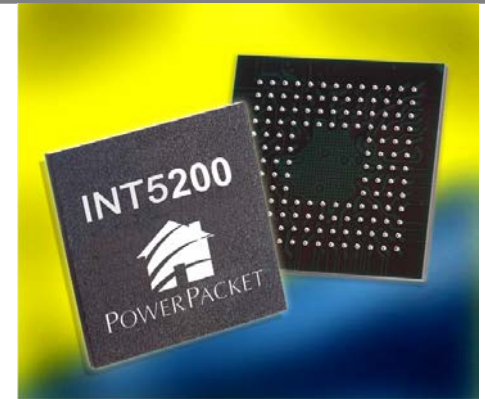

Benefits

- No New Wires!
- Data, Internet, File, Broadband and Printer Sharing
- Audio Extension
- Networked Gaming
- Ubiquity. Whole ouse coverage. Power outlets are everywhere.
- Ease of use. Just Plug It In!

INT5500 - HomePlug 1.0 with Turbo

- Key Features:
 - Peak performance of 85 Mb/s
 - HomePlug 1.0 compatible
 - Full-duplex Ethernet with MII
- Fully 1.0 Compliant
- 85 Mbps PHY rate
- Network throughput 10-15 Mbps
- Expands PL capabilities to SD video, IPTV, higher quality audio, ADSL2/2+, PL-802.11g bridge
- Compatible and compliant with HomePlug 1.0
- Soft MAC allows firmware updates to MAC as required



INT6000 - HomePlug AV

- 200 Mbps-class technology
- Multiple HD and SD streams
- Whole home coverage
- Enhanced QoS Capabilities
- Programmable Frequency Notching
 - Meets recommended limits for notching of amateur bands (-80 dBm/Hz)
- No initialization required by an external device
 - No resources required from Host processor
- Specification allows for compatibility with 1.0
 - It is not possible to interoperate with HP 1.0 without Intellon's patents
- Peak application throughput of 105 Mbps

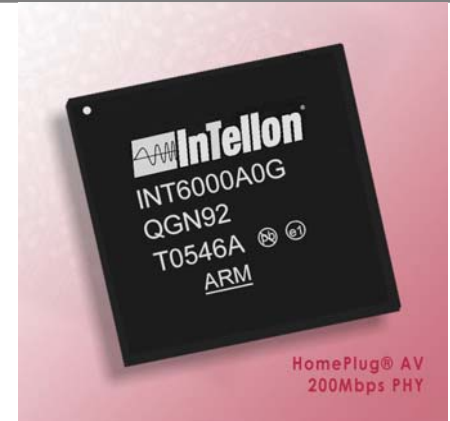

Intellon Product Feature Matrix

	HomePlug 1.0 (INT5200)	HomePlug 1.0 w/ Turbo (INT5500)	HomePlug AV (INT6000)
Applications	Data, VoIP	Data, WiFi Ext, VoIP, IPTV	HD&SD, Home Theater, Triple Play
PHY rate	14 Mb/s	85 Mb/s	200 Mb/s
Peak throughput	8 Mb/s	35 Mb/s	105 Mb/s
Typical Power Line throughput	4-6 Mb/s	8-12 Mb/s	40-45 Mb/s
FEC	Concatenated	Concatenated	Turbo Codes
Bandwidth	4-21 MHz	4-21 MHz	2-30 MHz
Host interfaces	MII, USB, Enet	MII, Enet	MII, Enet, PCI, TS
Channel Access (QoS)	CSMA/CA (4)	CSMA/CA (4)	TDMA,CSMA/CA (8)
Max modulation	DQPSK	256-QAM	1024-QAM

HPAV Delivers Superior Performance

Real-world tests reveal the superior performance of Intellon's HomePlug AV open-standard based powerline communications technology.

	Test	Qualifiers	Intellon HP AV	DS2	Panasonic
1	UDP, HD Video (Test Home)	20 Mbps each stream, 80% outlet coverage, *noise impaired	2 stream	0 streams	0 streams
2	UDP, SD Video (Test Home)	6 Mbps each stream, 80% outlet coverage *noise impaired	6 to 7 streams	3 streams	3 streams
3	TCP Test (Test Home)	90% outlet coverage, *noise impaired	36 Mbps	12 Mbps	15 Mbps
4	TCP Test (lab)	Maximum throughput with halogen lamp noise	44 to 46 Mbps	32 Mbps	23 Mbps
5	Noise Recovery Time	Lab test, halogen lamp turned on and off	46 to 59 Mbps in 6 secs.	20.5 to 42.5 Mbps in 80 secs.	21.5 to 49 Mbps in 10 secs.

Powerline devices must operate reliably in the presence of line noise!



HomePlugTM: The solution for simple, reliable, multimedia connectivity.

Intellon: partner for business success.



HomePlug Standards for Worldwide Multimedia In- Home Networking and BPL

ISPLC 2007

Haniph Latchman & Richard
Newman

March 27, 2007



Agenda

- HomePlug C&C and BPL Roadmap
- HomePlug AV Logo Certification Program
- HomePlug AV Architecture
- HomePlug AV Advantages
- Q&A



HomePlug C&C & BPL Roadmap

HomePlug Powerline Alliance
February 2007

Broadband Over Powerline (BPL) 2007 Roadmap

- Q1: Simulation Testing
- Q2: Candidate BPL Spec
- Q3: Ratified BPL Spec and Field Testing
- Q4: Prototype BPL Products

Command and Control (C&C) 2007 Roadmap

- Q1: Candidate C&C Spec to BOD
- Q2: Ratified C&C Spec
- Q3: Field Testing
- Q4: Prototype C&C Products



HomePlug AV Logo Certification Program

Charter

Implement a Compliance & Interoperability certification program to ensure delivery of robust HPA technology compliant and interoperable HomePlug technology components

Test Components

- Compliance Certification Testing
 - Testing of individual chipset solutions for compliance to the AV specification
 - HomePlug AV technology specification compliance checklist
- Interoperability Certification Testing
 - Testing of products with each other
 - Products submitted for testing must contain chipset solutions that have passed the Compliance testing process
 - HomePlug identified system profiles with performance and interoperability requirements
- Testing on a standardized test platform
 - Test & Test Bed definition available to members.

HomePlug TM & Logo

- 1st Phase Programs
 - Early adopter testing
 - Products passing both test programs are granted license to use the HomePlug TM and “Designed for HomePlug AV” marking
- 2nd Phase Programs
 - Full certification testing
 - New test tools will allow more detailed and greater test coverage
 - Products passing both test programs are granted license to use the HomePlug TM and Certification Logo
- HomePlug TM & Logo is for end user assurance and vendor marketing
- Updated guidelines will be available late February on the HomePlug website

Opportunity for companies to participate and leverage marketing opportunities of the program and logo.

Workshops & Plugfests

- Compliance Workshops & Interoperability (C&I) Plugfests
 - Compliance testing to be under the direction of HPA
 - HPA maintains company compliant “pass only” list
 - “List” made available to integrators per formal HPA request
 - Events executed at a HomePlug contracted test house by 3rd Party C&I experienced technologists
 - Perform testing
 - Provide test reports (confidential only)
 - Technical support
 - Issue resolution

Compliance & Interoperability Test Events

- 1st Phase 1 Compliance & Interoperability Test Events
 - Test events held in December 2006 at the HPA Test House
 - 14 products from 11 companies passed interoperability testing and were granted license to use “Designed for HomePlug AV” mark
 - Second Interoperability test event to be held in the March/April 2007 timeframe
- 2nd Phase Compliance & Interoperability Testing
 - Development is currently underway
 - Test event dates targeted for June 2007
 - Full compliance testing
 - Passing products will be granted license to use HomePlug certification logo



HOMEPLUG EXECUTIVE SEMINAR

PROVEN WORLDWIDE STANDARDS

HomePlug AV – Detailed Architecture

HOMEPLUG AV PHY AND MAC TECHNICAL OVERVIEW

Agenda

Networking in the Digital Home

The HomeplugAV MRD

Technical Overview

- PHY
- MAC
- Bridging to Other Network Types

Summary

Digital Home – Communication Focal Point

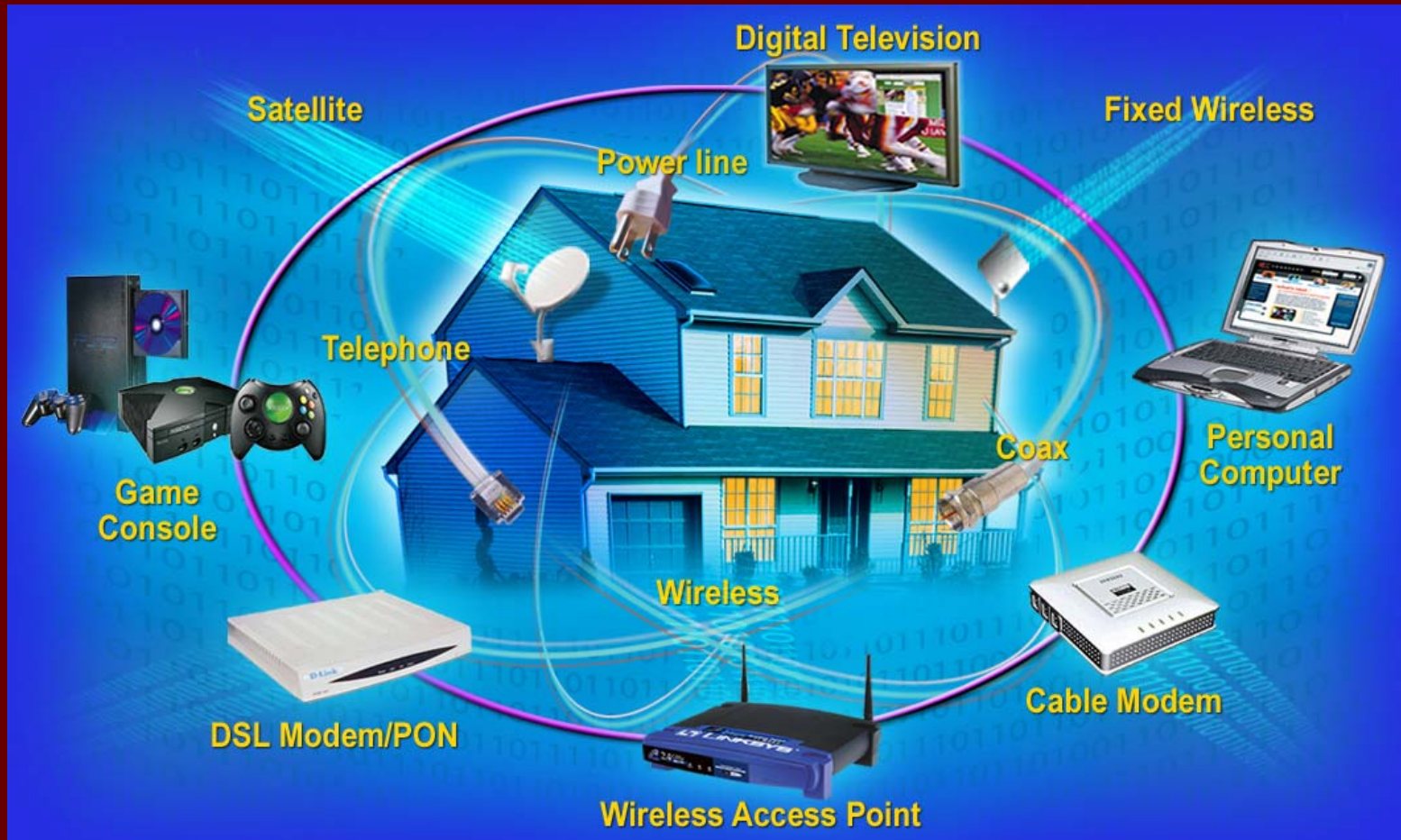

The Digital Home Still
Lacks a Backbone Network
Strategy...

Candidate Wired Technologies

Medium	Standard	Actual Throughput	Guaranteed QoS	No new wires	Multi-sourced	Whole House Coverage	NDA / IPR issues
CAT5	Ethernet (1G)	✓ ✓	-	✗	✓	✗	✓
Phoneline	HomePNA 3.0	✓	✓	-	✗	-	✓
Coax	MoCA	✓	✓	-	✗	✗	✗
Powerline	HomePlug AV	✓	✓	✓	✓	✓	✓

HomePlug AV – Best Suited for Wired Backbone in the Digital Home

Application scenarios

Application App. Rate Mbps	Scenario 1 Two Person family		Scenario 2 Six-person family with small children		Scenario 3 Six-person family with small children & teenagers	
	Qty	App. Rate Mbps	Qty	App. Rate Mbps	Qty	App. Rate Mbps
HDTV Home Theater @ 22 –27.8	1	22 – 27.8	1	22 – 27.8	1	22 – 27.8
SDTV @ 3 - 7	1	3 - 7	3	9 - 21	2	6 - 14
Home Theater Audio @ 5.4	1	5.4	1	5.4	1	5.4
CD Audio @ 0.8 x 2					3	4.8
Phone- VoIP @ (.064 + .016) x 2 = .160	2	0.16	2	0.16	3	0.24
IP Data @ 2	2	4	2	4	5	10
Total	6	34.5 – 44.4	9	40.6 – 58.4	15	48.4 – 62.2

HomePlugAV MRD focused on media delivery

HomePlug AV MRD – Designed for media

Marketing Requirements Document built first

Focus segment

Consumer Electronics (STB, HDTV, DVD, Audio)

Focus applications

Video and Audio distribution

Voice and Data

Performance requirements

>100Mbps, whole home coverage for high quality streaming media

Reliable, Secure delivery with low latency and jitter

Efficient use of available system capacity, with graceful degradation

Acceptable for encrypted, copy protected content with DRM

Coexistence

With 1.0, X10, LonWorks and CEBus

Easy bridging to other networking technologies

Coverage

At least 98% of outlet pairs must support a single 24Mbps HDTV stream

At least 90% of outlet pairs must support two simultaneous 24Mbps HDTV streams

All at a competitive cost

No infrastructure upgrade cost + Competitive node cost = a winning technology

System Architecture Overview

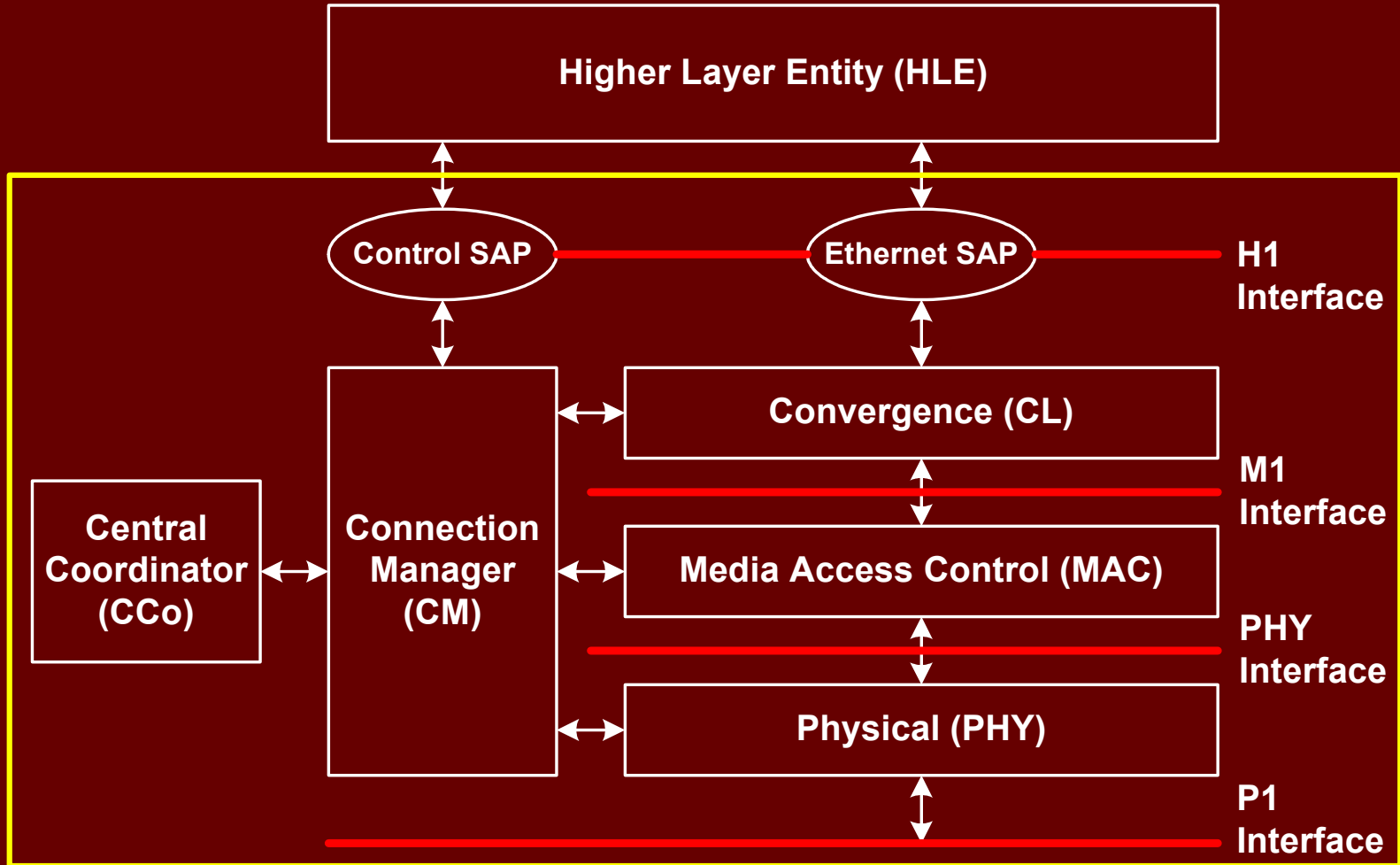

PHY Overview

Windowed OFDM

- Spectral notching for preamble, frame control and payload
- 917 carriers (excluding Amateur bands) in USA

Bit-loaded modulation: BPSK to 1024QAM

- Optimum adaptation for each connection

Turbo FEC for frame control, beacon, payload

- 16, 136 and 520 byte block sizes respectively
- Near capacity performance (1.2 dB from Shannon Capacity)
- 20-30% improvement over conventional codes
- Most improvement seen on poorest channels, where needed most

Channel interleaver for impulse noise and other PL impairments

Diversity coding for reliable frame control, beacon and ROBO

HP1.0 coexistence mode uses 1.0 preamble and frame control

- AV preamble can be detected by 1.0 devices

200 Mbps PHY channel rate

- 150 Mbps PHY information rate

Common PHY for in-home and BPL technologies

Turbo Code Performance – HW, 4 bit LLR*

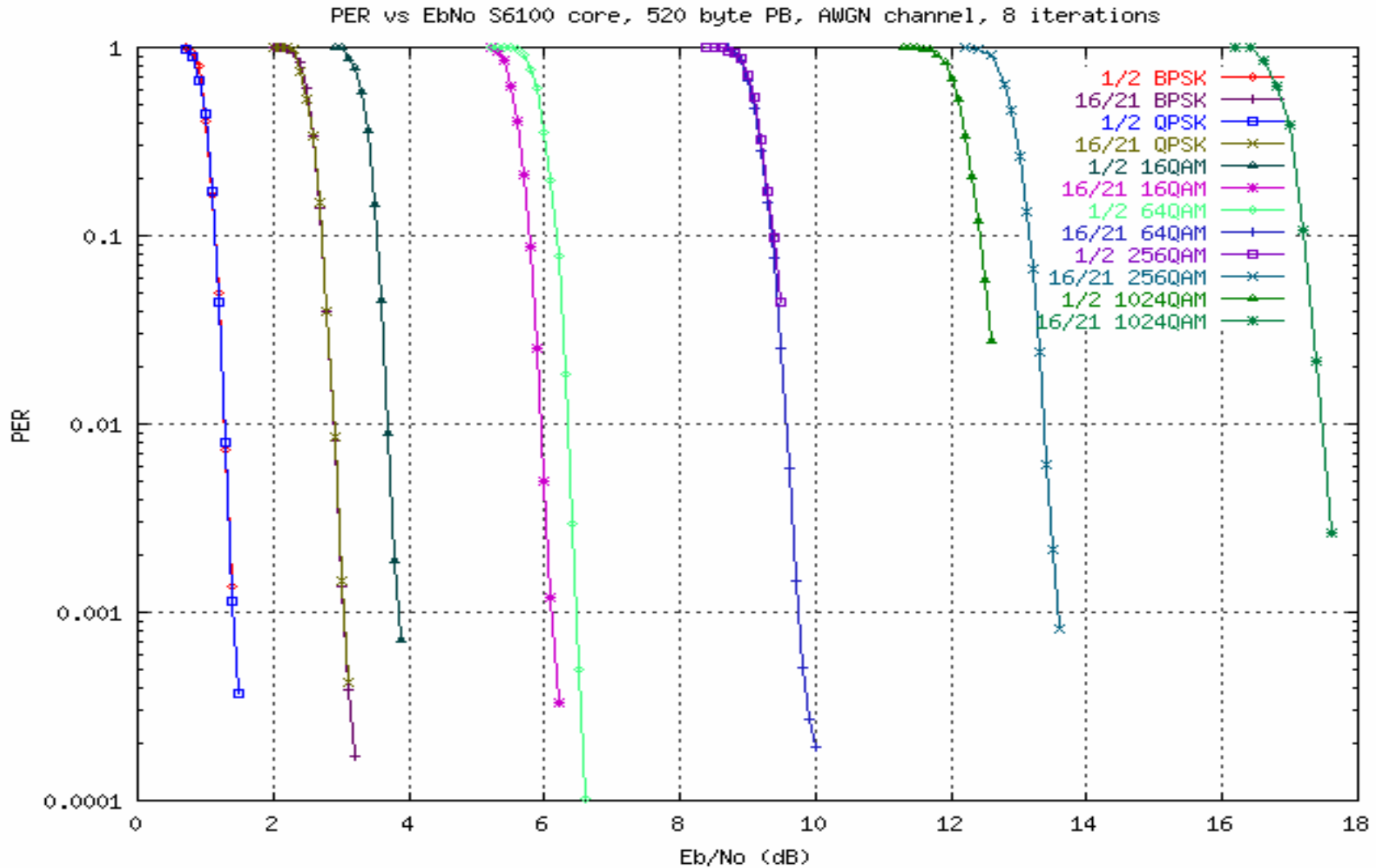

*Note: Graph provided by iCODING Technology Inc.

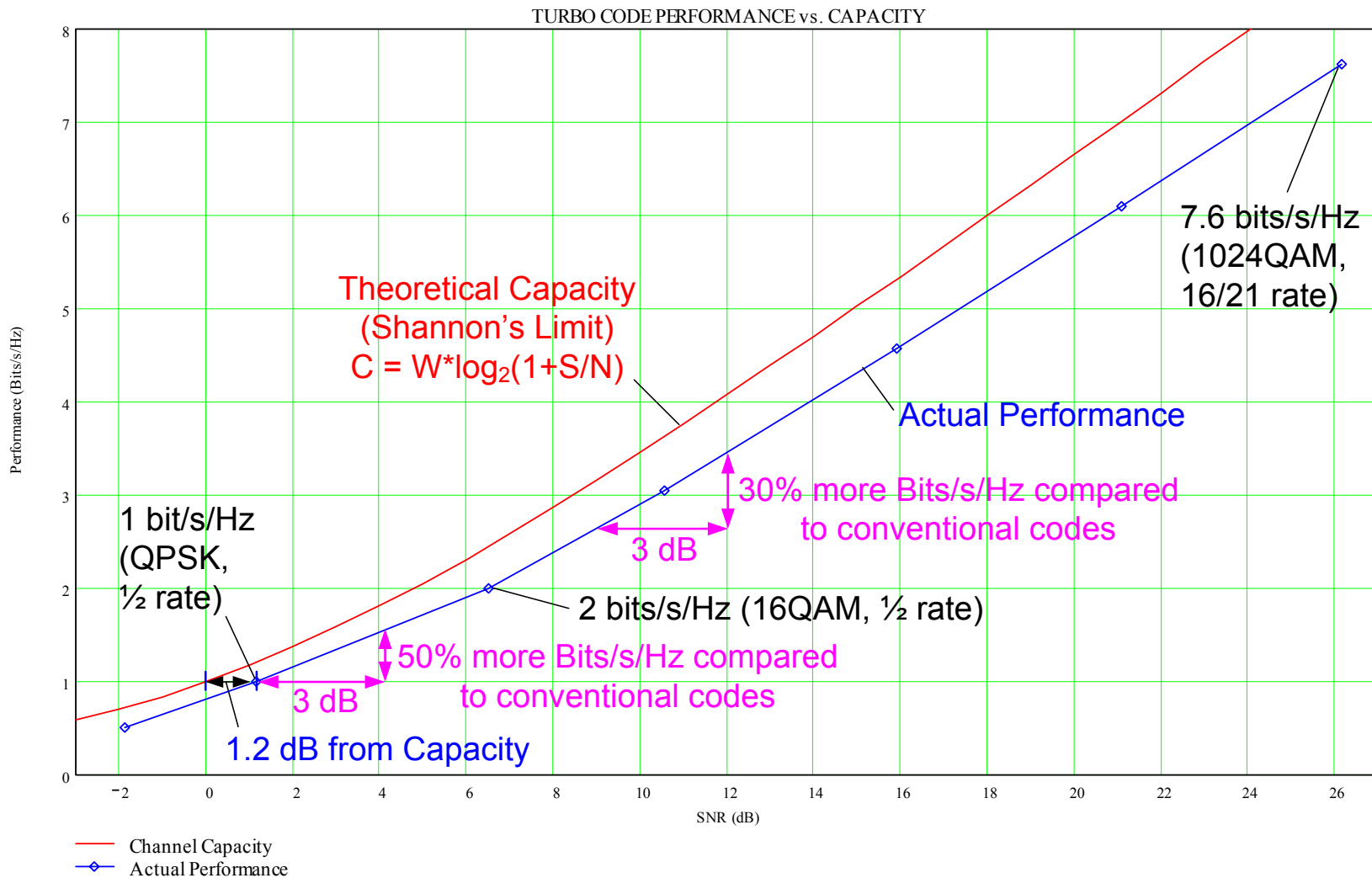

PHY Spectrum

Windowed OFDM – 917 channels from 2-28 MHz

- Easy, efficient, configurable creation of nulls to satisfy regulations
 - Dynamically controlled by CCo
- Well suited to frequency selectivity of power-line channel (see next slide)
- Technology can be easily extended to frequencies above 30MHz
 - Tone Mask Vs Amplitude Map

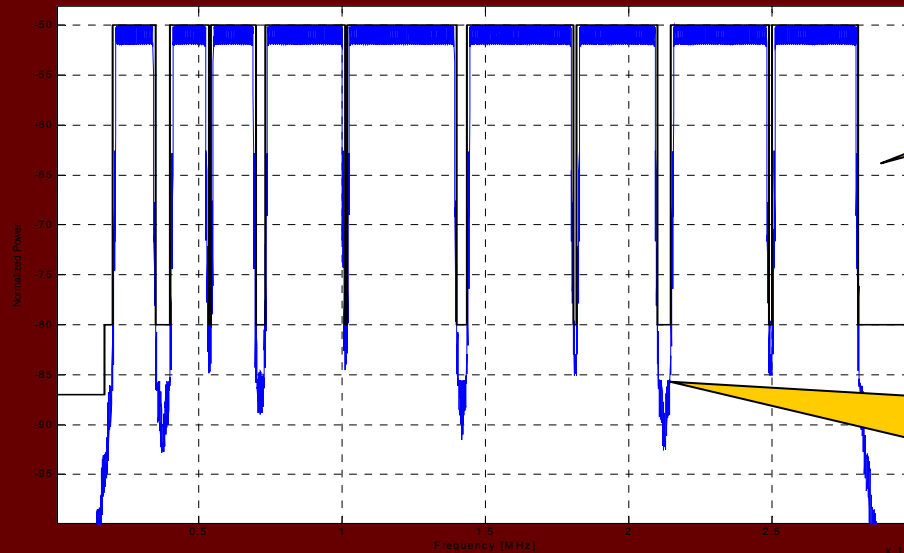

Power Spectral Density Vs Frequency

Nulls created simply through configuration. Spectral nulls required to avoid interference with amateur bands. Different rules in different countries

PHY Performance Test – 10 Homes

80% of outlet pairs

- 55 Mbps or better

95% of outlet pairs

- 35 Mbps or better

98% of outlet pairs

- 27 Mbps or better

Typical PHY data rates

- 70-100Mbps

Typical PHY Channel

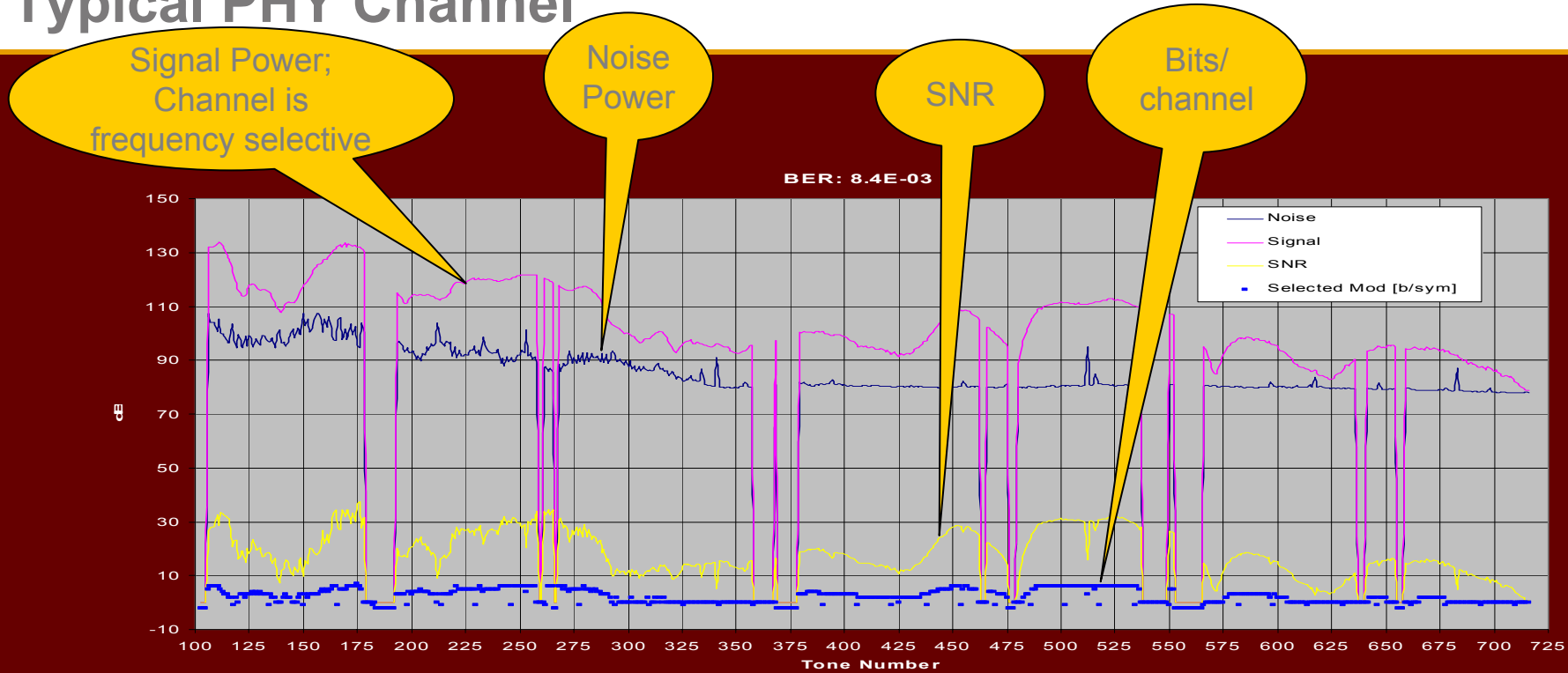

Each tone (AKA OFDM channel) loaded with 1, 2,3,4,6,8, or 10 bits

Up to 200 Mbps channel and 150 Mbps information rate (after FEC)

Includes Robust modes for broadcasting control and user info

Turbo FEC (error correction) for near-capacity performance

HomePlug AV MAC Overview

Centrally managed network (by CCo)

Three access methods within a network:

- Beacon: Non-contention. CCo transmits Beacon in dedicated slot
- Contention-free: Only designated station transmits. QoS guarantee.
- CSMA: Contention-based. Exchange of priority-based user data and management messages.

Beacon Period is divided into “Regions”.

- Schedules specified in Beacons.
- Different allocations are further specified in some Regions.

Allocations: persistent, or non-persistent (valid for current BP only).

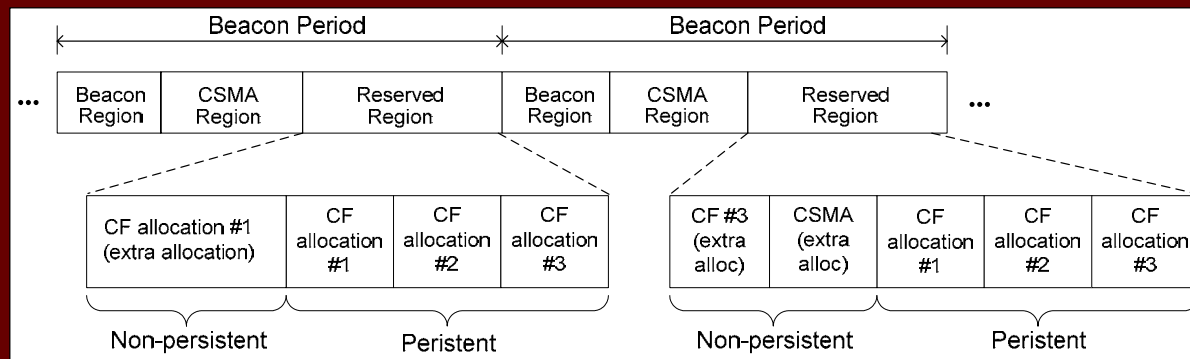

Beacon Period Regions

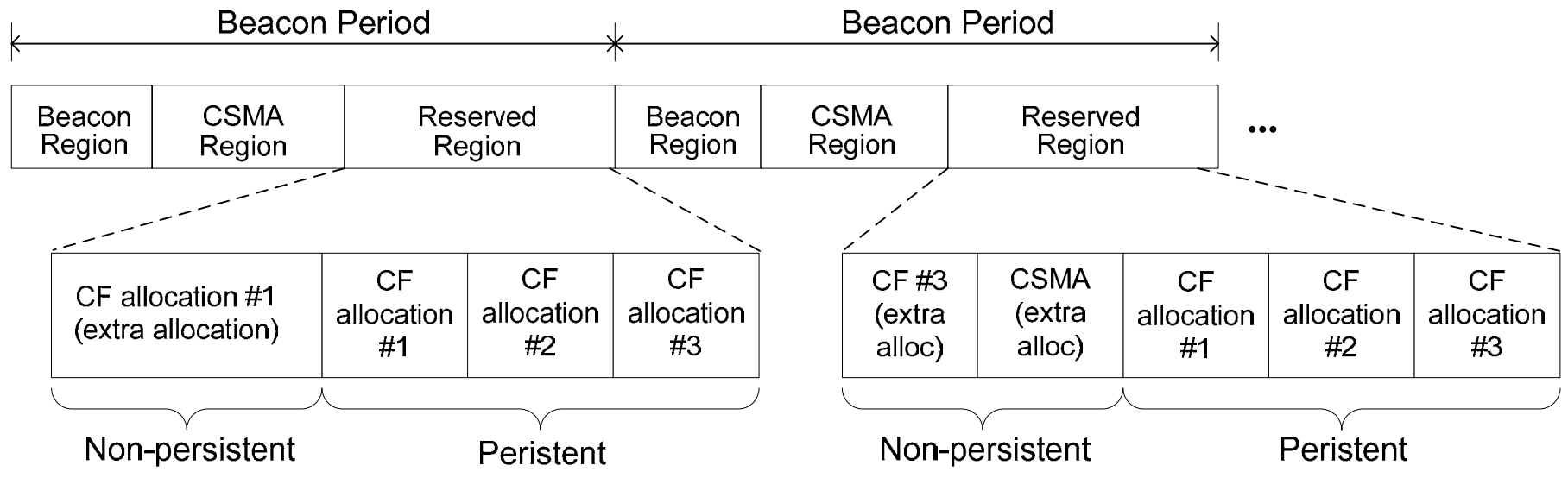

HomePlug AV MAC Overview

Beacon Period synchronous with AC line cycle.

Networking timing and synchronization

Channel adaptation and recovery procedure

Partial ACK for broadcast and multicast

Bridging

Data plane

- Segmentation and reassembly
 - MSDU + Header to form MAC Frame
 - MAC Frames are segmented and form PHY Blocks
 - Multiple PBs are sent in a PPDU
- Jitter control – arrival time stamps are optionally added to MSDUs.
- Encryption – 128 bit AES (each segment is encrypted separately)
- Packet bursts – up to 4 SOFs before sending a SACK.
- ARQ, SACK and retransmissions

Beacon Period

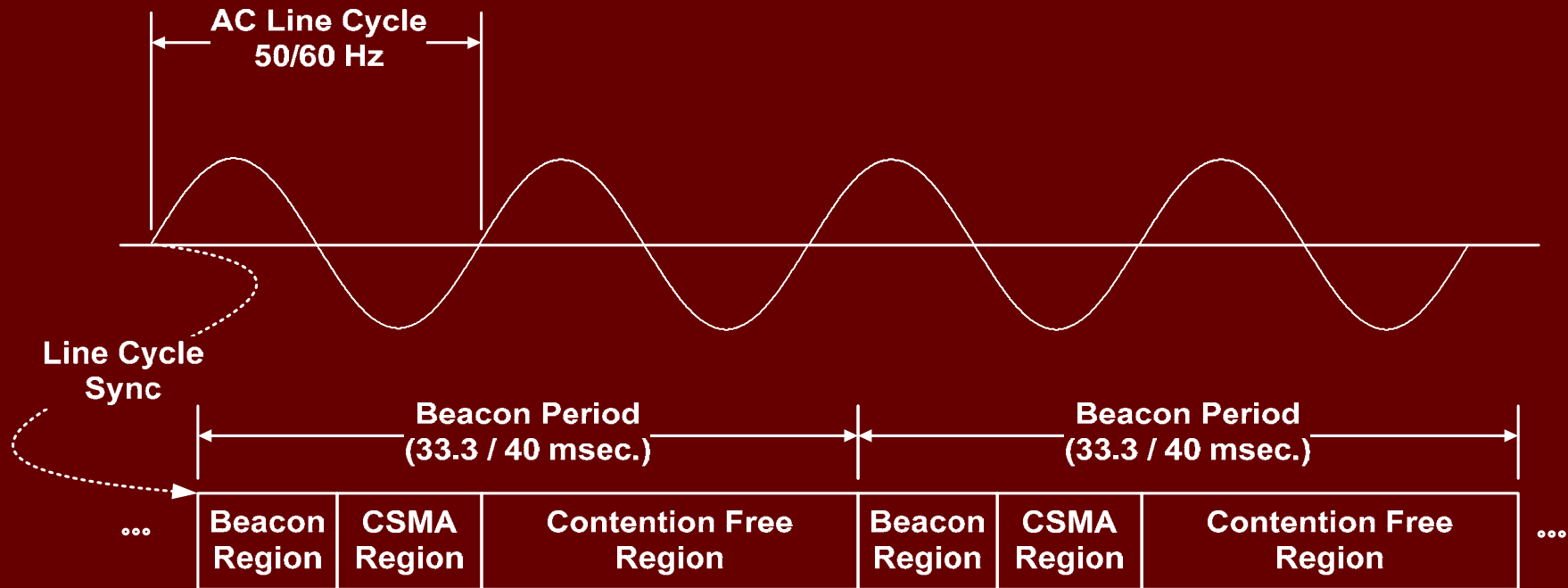

Three regions:

- Beacon region, CSMA region, Contention Free region (TDMA)

Schedule of regions and Contention Free allocations broadcast in the beacon
Beacon period synchronized to AC line cycle

MPDU Format

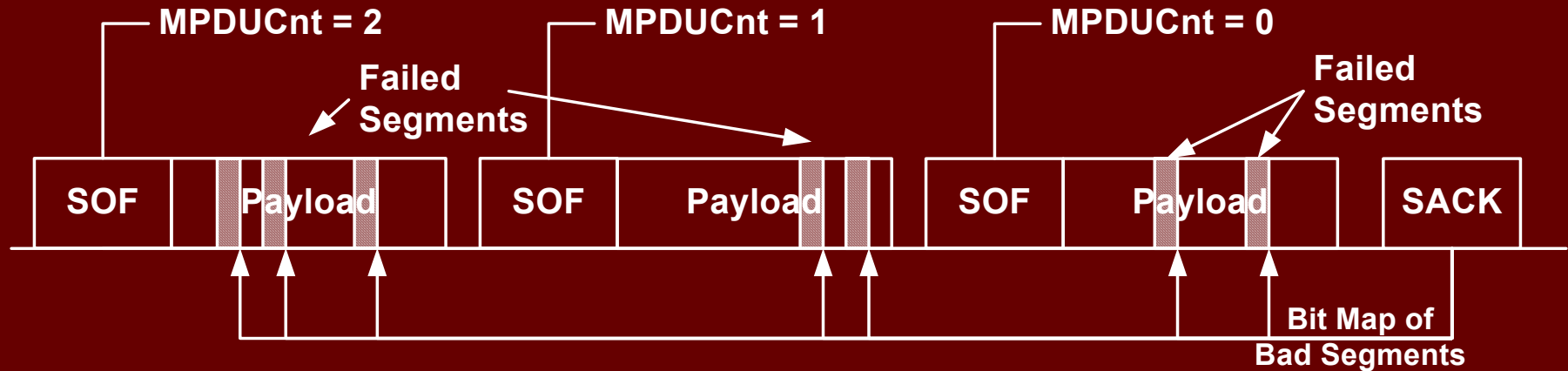

MSDU stream (from Convergence Layer) is segmented into 512 byte blocks

- Segment + header + CRC = Turbo FEC block

Segments are transmitted in MPDUs (to PHY)

Segments are selectively acknowledged (SACK)

Bridging

Source-Aware Ethernet Bridging

- Provides high-speed communication between bridged devices
- Efficiently accommodates unicast, multicast and broadcast traffic
- Seamless pass-through communication between networks

QoS is utilized and preserved

- Promiscuous traffic type identification
- Dynamic generation of AV Connection Specifications (CSPEC's)
- QoS is passed onto another bridged network if necessary
- QoS is utilized and preserved

Connection management/Tone Map Management

Connection Management

- Stations exchange QoS requirements (CSPEC) and set up a connection.
- CSPEC contains min./avg./max. data rate, delay bound, etc.
- If contention-free allocation is needed, stations then send BW request to CCo.

Channel Estimation and Tone Map Management

- Stations exchange SOUND PDUs to find out channel characteristics and to determine optimal tone maps (e.g., modulation per tone, and cyclic prefix length).
- Stations also continuously monitoring PB error rate to update tone maps.
- Different tone maps may be used in different intervals of the AC line cycle. (Made possible by synchronizing Beacon Periods to line cycle.)

Service Access Points - SAPS

Data SAP

- MSDUs are Ethernet format
- Leverages existing infrastructure
- Simple bridging to Ethernet networks

Control SAP

- Access to MAC features
- Primitives defined in specification

Management messages allowed over the Data SAP

- Support for “Ethernet Adaptors”

Convergence Layer

Between HLE and MAC

Data SAP

Classifier

- Identify different streams from single SAP

QoS monitoring

- Stream performance statistics, reconfigure

Automatic connection service

- For applications that cannot request QoS

Smoothing service (jitter control)

- Important for audio and video streams

Central Coordinator – CCo

Beacons transmission

- AC line cycle sync, network clock, & schedule

Association, authentication & security

- Admit new stations into network

Admission control and bandwidth management

- Determine schedule that meets QoS requirements.
- Persistent allocation provides coarse-scale allocation.
- Real-time adjustment made based on stations' queue depth.

Neighboring network coordination

- Coordinate sharing of BW between neighbor CCoS.

Central Coordinator - CCo

Discover Process

- Each station takes turn to transmit Discover Beacon.
 - Allow other stations to update network topology.
 - Allow hidden stations (HSTAs) to join the networks.
- CCo periodically polls stations to update its network topology table.
 - Can be used to select a better CCo, and aid in neighbor network coordination.

Proxy Networking

- HSTA sends association message to station (PSTA) transmitting the Discover Beacon
- PSTA forwards such message to CCo.
- CCo appoints PSTA as Proxy Co (PCo).
- PCo relays future management messages between HSTA and CCo.

Quality of Service (QoS)

Connections

- Parameter Based QoS (TDMA)
- Priority Based QoS (CSMA)

Higher Layer Entities (HLEs)

- Connection Specification (CSPEC) and Control
- QoS Management and Control

Connection Manager (CM)

- Connection Management and Monitoring

CCo

- Bandwidth Management and Scheduling
- Link “squeeze” and “desqueeze”

Quality of Service (QoS)

Convergence Layer (CL)

- Packet classification, QoS Monitoring, etc.

Higher Layer Enhancements

- Reverse Grant
- Allows “sender” to give “receiver” time on wire
- Especially important for TCP

Security

Data Protection (Privacy)

- NEK: Encryption with rotating Network Encryption Key
- Inherent privacy with Tone Maps

Authentication: Gaining Network Access

- NMK: Network Membership Key used to distribute NEK

Authorizing a New Station with NMK

- Direct entry of NMK
- DAK: Remote distribution of NMK with Device Access Key
- Simple Connect “push button” distribution of NMK
 - Made mandatory for universal interoperation
 - “Add” mode and “Join” mode – depends on AVLN membership
 - Two “Joiners” will also create AVLN

Supports HLE protocols such as 802.1x, EAP, etc.

Neighbor Networks

AVLN Formation

- One Physical Network & Many Logical Networks (AVLNs)
- Cryptographic isolation, AVLN definition
- Device failure to authenticate with existing networks =>
becomes “unassociated STA”
- If no other network or two STAs share key, STA starts a new neighbor network

Coordination

- Each network has its own Beacon Slot in the Beacon Region to transmit its Beacon
- Networks partition beacon cycle into usage regions

Neighbor Networks

Interfering Network List (INL):

- Contains networks that AVLN interferes with
- A network coordinates with networks in its INL (i.e., no chaining effect) to share the channel.

Synchronization

- CCo using the first Beacon Slot synchronizes to the AC line cycle; all other CCo synchronizes to it.

Region Allocation

- CCo of NNs exchange bandwidth needs information
- Arrange periods of usage according to policy and needs

CSMA-Only Mode

- When coordination not reliable, CSMA transmission of beacons
- All access is CSMA
- Natural channel reuse

Neighbor Networks

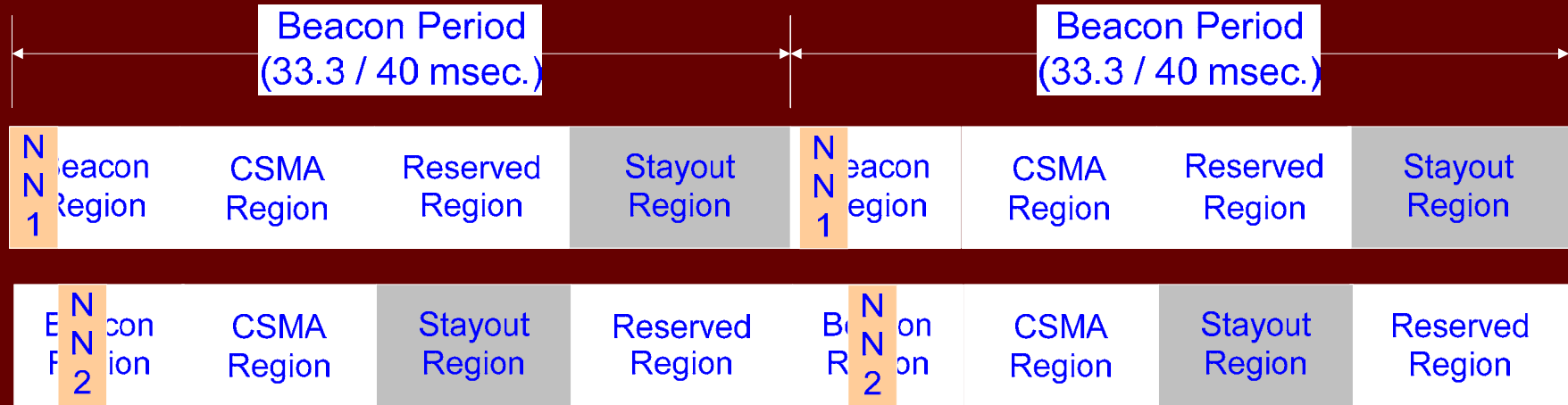

- Neighbor Networks 1 & 2 interfere with each other.
- When NN1 specifies Reserved Region, NN2 must specify Stayout Region.

Neighbor Networks

Key concept:

- Different Regions:
 - Reserved Region: contention-free transmissions.
 - Stayout Region: no transmissions.
 - CSMA Region: random access.
 - Beacon Region: Multiple Beacon Slots.
- Network can specify Reserved Region only if INL has accepted its BW request.
- CSMA Region may be overlapped among INL.
- Network must specify Stayout Region if INL has specified a Reserved Region.

Advantages:

- Coordination allows guaranteed QoS in Reserved Region.
- Spatial reuse is possible.

Neighbor Networks

Neighbor Network Requesting Bandwidth MSC

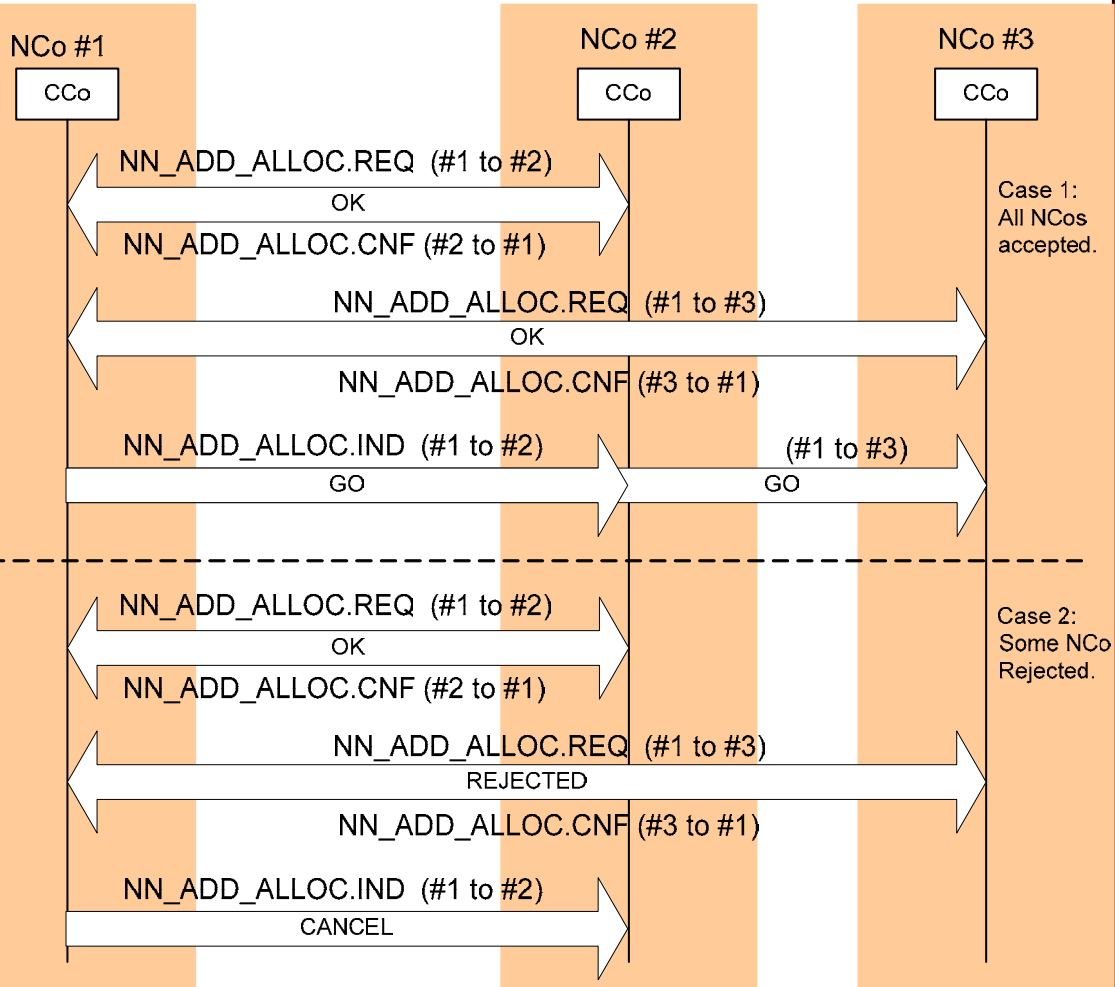

Example of requesting bandwidth. (all 3 networks interfere with each other)

Case 1:
All NCoS accepted.

Case 2:
Some NCoS Rejected.

Summary

HomePlugAV Provides best in class coverage and capacity of any home networking solution

HomePlugPAV perfectly suited to be the wired backbone for the home

- **HomePlug AV Provides the Most Ubiquitous Wired Networking Solution for AV Content**
- **HomePlug AV is complimentary to wireless networks**

HomePlugAV Physical Layer:

- **Robust Operation on the Powerline**
- **Efficient Programmable frequency notching for world-wide deployment**
- **Seamless and efficient coexistence between in-home and BPL**

HomePlugAV MAC Layer:

- **Highly Efficient Operation with both Media and non-media Data Types**
- **Industry Leading Security**
- **Outstanding QoS**



Advantages of the HomePlug AV Technology

HP AV Physical Layer (PHY) Advantages

- HP AV PHY based on Windowed OFDM
 - flexible frequency notches is common to all technologies
 - HP AV uses an OFDM guard interval to manage delay spread of the powerline channel
- HP AV uses advanced forward error correction (Turbo Convolutional Codes) to operate near channel capacity
 - 1.2 dB from theoretical capacity
 - conventional codes operate 4 dB or more from capacity, resulting in lower throughput performance on noisy powerline channels
 - Turbo Codes provide 20-30% more throughput
 - significant performance improvement on poor channels, where improvement is most needed

Turbo Code – Performance vs. Capacity

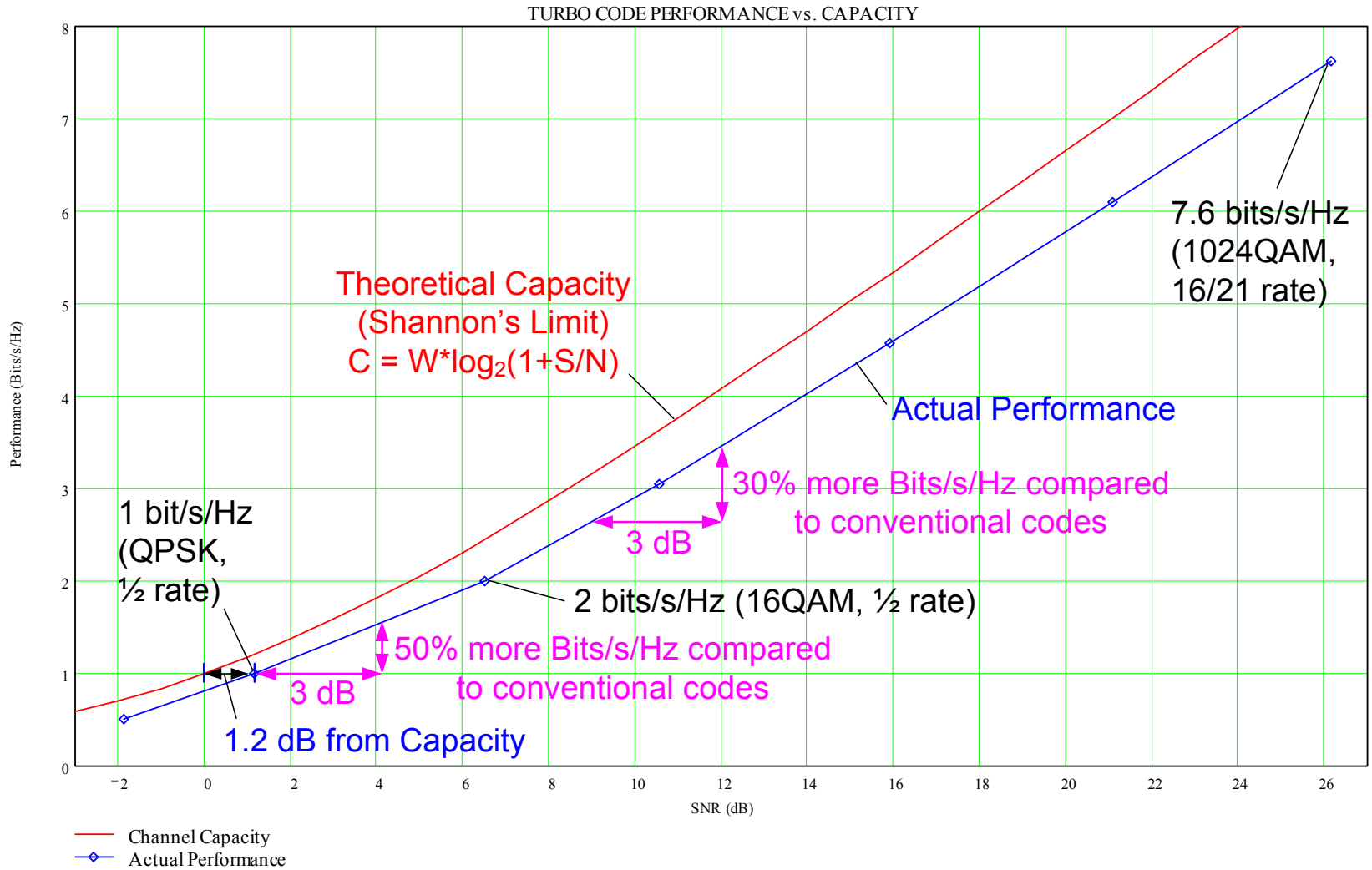

HP AV Physical Layer (PHY) Advantages (2)

- HP AV channel adaptation is synchronized to the AC line cycle
 - powerline noise is commonly synchronous with the AC line cycle
 - dimmers, brush motors, switching power supplies, halogen lamps
 - performance improvement of 20% or more is typical
 - without this feature, channel adaptation must use worst case noise (slowest)

Channel Adaptation and Powerline Noise

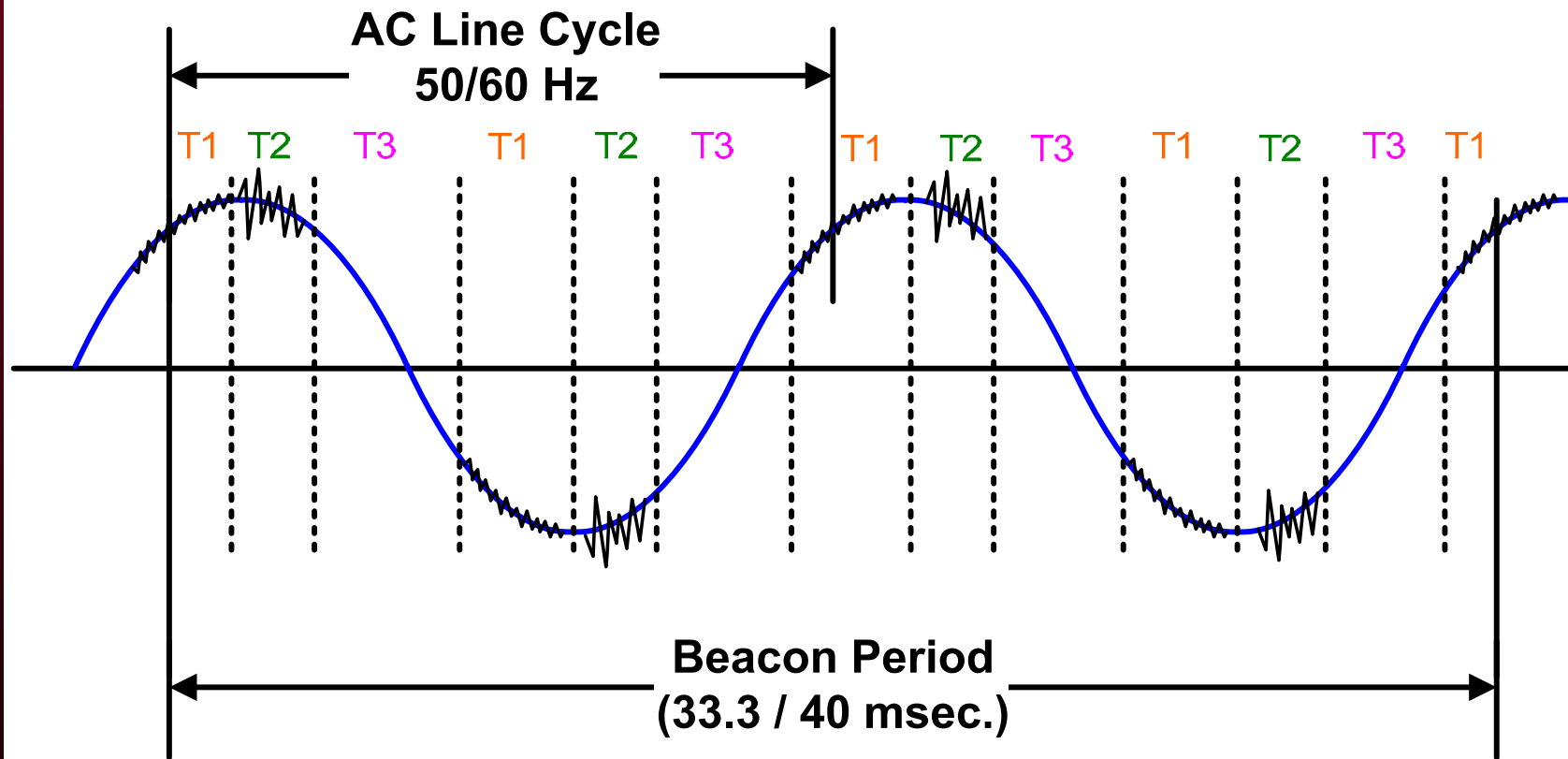

HP AV Media Access Control Layer (MAC) Advantages

- HP AV Beacon Period and TDMA allocations are synchronized to the AC line cycle
 - this feature provides reliable beacon transmissions
 - this feature also provides stable TDMA allocations with powerline noise
 - managing TDMA schedules is difficult without AC line cycle synchronization
- HP AV employs dynamic TDMA
 - this feature provides noise tolerant beacon schedule
 - this feature provides very fast TDMA allocation changes when channel or traffic changes
 - managing fast changing powerline channels or traffic data rates is difficult without this feature

TDMA Allocations and Powerline Noise

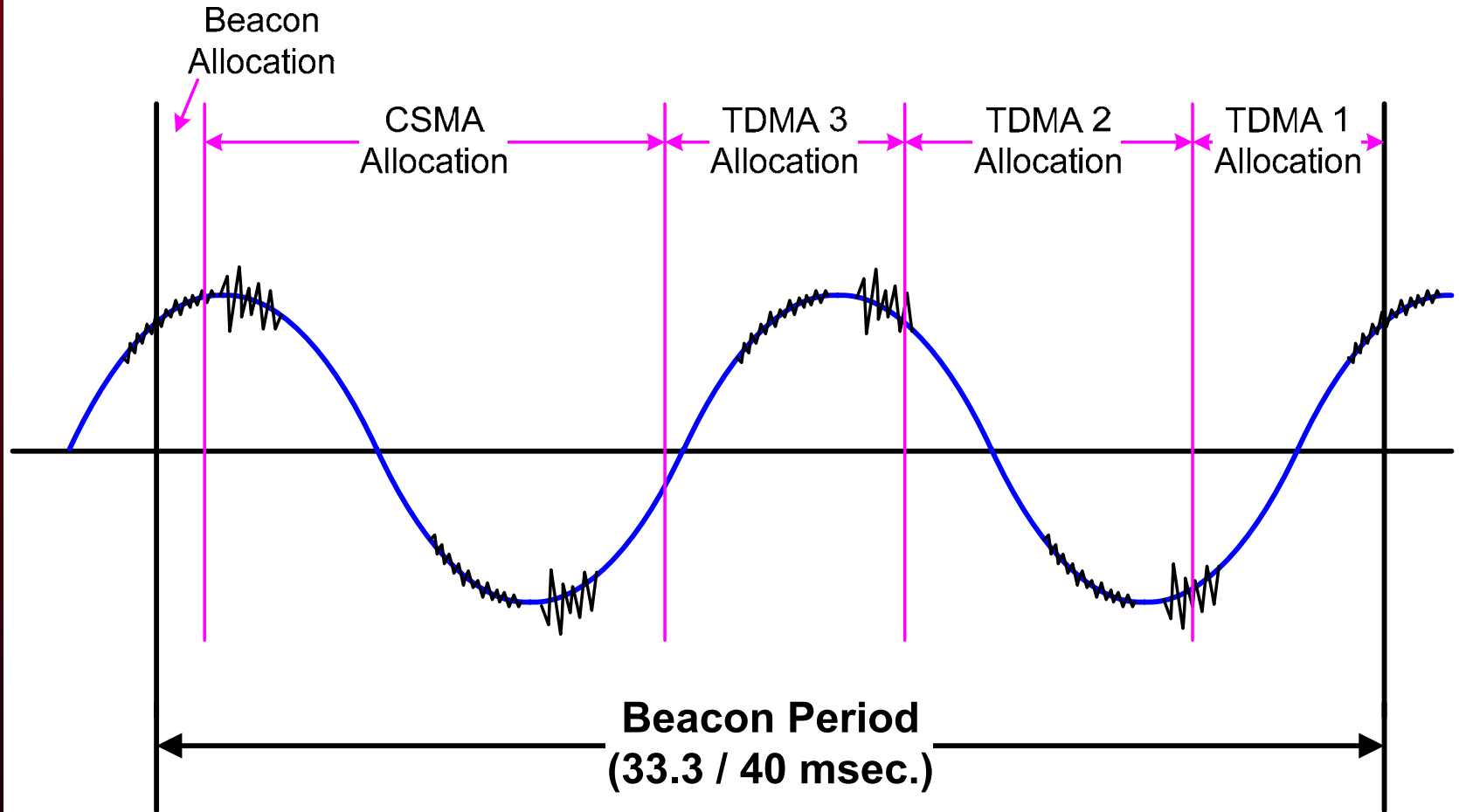

HP AV Media Access Control Layer (MAC) Advantages (2)

- HP AV uses very efficient segmentation and reassembly, and MSDU (packet from host) concatenation
 - this feature provides optimum performance for retransmission of lost segments due to powerline channel noise bursts
- HP AV provides a sophisticated neighboring network solution
 - enables TDMA allocations in the presence of neighboring networks
 - enables reuse of the powerline channel
 - supports various layers (topologies) of neighboring networks
- Protocol for efficient TCP performance
 - optimized to provide low latency, low overhead bidirectional traffic
 - provides near UDP performance in CSMA and TDMA allocations
- Simple network setup
 - secure push button mechanism for encryption key distribution
 - close proximity between devices is not necessary

HP AV Advantages

- HP AV is the only PL technology jointly developed from the best technologies of multiple leading companies
- HP AV is the highest performing solution available based on numerous independent tests and reviews
- HP AV is the only PL technology that met the stringent “coverage” requirements of the HomePlug MRD
 - 98% of all connections support one 24 Mbps HDTV stream
 - 90% of all connections support two 24 Mbps HDTV streams
- HP AV is recognized worldwide
 - provides coexistence between all HomePlug technologies, in-home and access
 - over 7 million HomePlug devices deployed worldwide
- HP AV is the only technology that has multiple IC suppliers
 - at least 5 known HP AV sources, more expected:
 - Arkados, Conexant, Intellon, Gige, Spidcom
- Members of the HomePlug Powerline Alliance benefit from the RAND licensing built into all membership agreements.
 - this approach makes the vast body of patents covering the technology open to the Alliance members.



Thank You!

Q & A

HPAV Delivers Superior Performance

Powerline devices must operate reliably in the presence of line noise!

Real-world tests reveal the superior performance of Intellon's HomePlug AV open-standard based powerline communications technology.

	Test	Qualifiers	Intellon HP AV	DS2	Panasonic
1	UDP, HD Video (Test Home)	20 Mbps each stream, 80% outlet coverage, *noise impaired	2 stream	0 streams	0 streams
2	UDP, SD Video (Test Home)	6 Mbps each stream, 80% outlet coverage *noise impaired	6 to 7 streams	3 streams	3 streams
3	TCP Test (Test Home)	90% outlet coverage, *noise impaired	36 Mbps	12 Mbps	15 Mbps
4	TCP Test (lab)	Maximum throughput with halogen lamp noise	44 to 46 Mbps	32 Mbps	23 Mbps
5	Noise Recovery Time	Lab test, halogen lamp turned on and off	46 to 59 Mbps in 6 secs.	20.5 to 42.5 Mbps in 80 secs.	21.5 to 49 Mbps in 10 secs.