

An Overview to New PLC Applications and New Challenges

Kaveh Razazian

Maxim Integrated Products



Outline

- An overview to G3 PLC specification
- Smart grid applications and the technical challenges
- New application areas that are evolving beyond smart grid such as automotive EV charging, lighting and industrial automation.
- Standardization
- Conclusion



G3-PLC specification

Robustness

MV / MV, MV / LV & LV / LV

High data rate

IPv6 compliant

Secure

Open specification

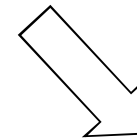
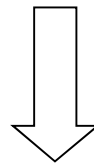
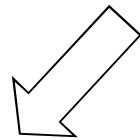

Low density areas

High density areas

**Smart Grid
and additional
services**

"G3-PLC" Smart Grid Solution Summary

Complete PLC modem for the Smart Grid
(from the PHY to the Application layer)

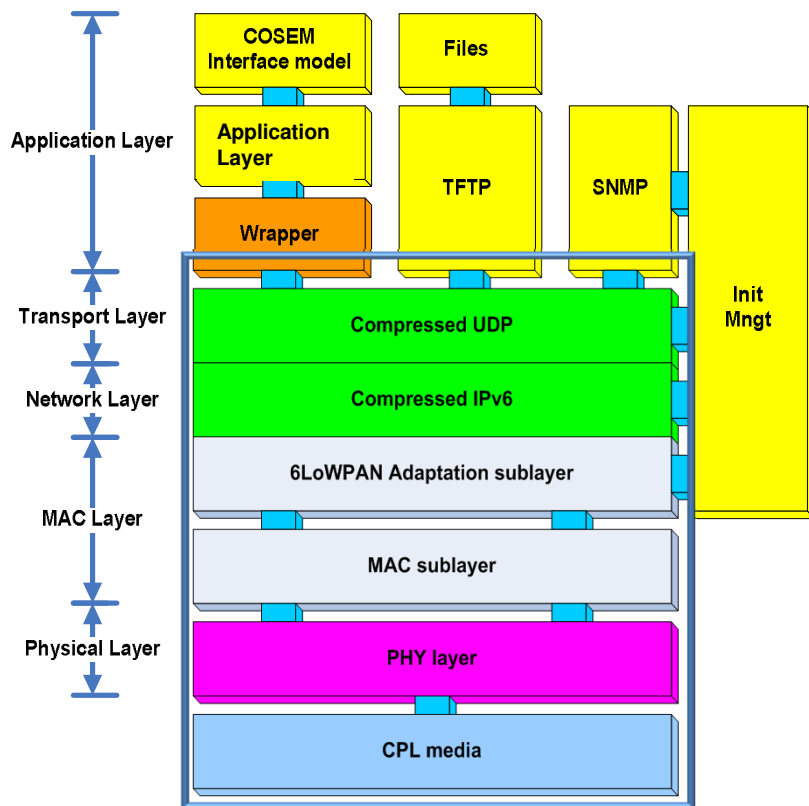

- **Application Layer**
 - Compliant ANSI C12.19/C12.22, IEC 62056-61/62 (DLMS/COSEM) or other standards used world wide
- **Transport and Network Layer**
 - IPv6 enables potential services: SNMP, TFPT, etc
 - Adaptation layer 6LowPan associates the MAC Layer 802.15.4 to IPV6:
 - Compression of IP header, fragmentation, routing, authentication.
- **MAC layer**
 - Plug and play network management to choose “Best Path” (Full Mesh Support)
 - Time domain and collision management
 - MAC Layer IEEE 802.15.4-2006
 - CSMA/ARQ
- **Physical Layer**
 - Support of internationally accepted bands from 10kHz - 490kHz (FCC, CENELEC, ARIB)
 - Multi-layer error encoding/decoding
 - Viterbi, Convolution, Reed Solomon and CRC16
 - 8psk, QPSK, BPSK, Robo, Messaging Mode
 - Adaptive Tone mapping, notching and modulation

G3-PLC Data Rates and BER plots

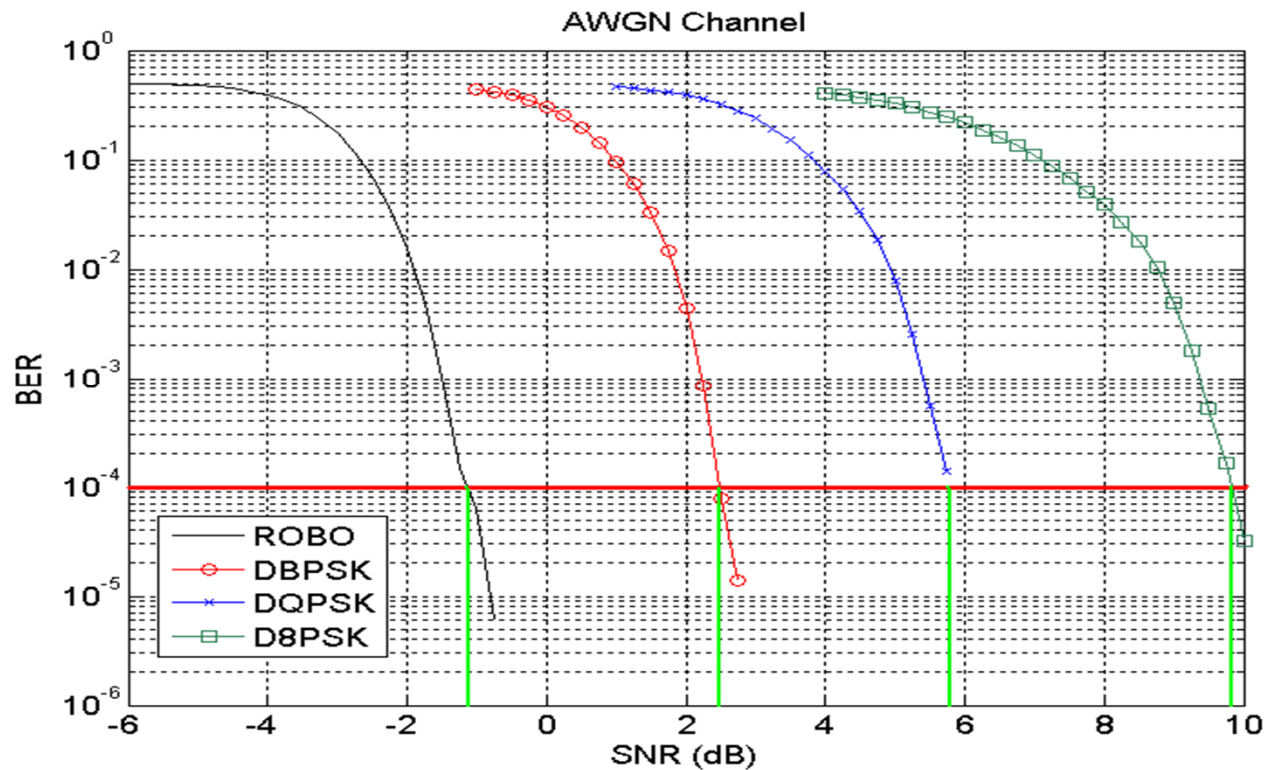

Frequency Band	Typ Robo Data Rate (bps)	Typ DBPSK Data Rate (bps)	Typ DQPSK Data Rate (bps)	Typ D8PSK Data Rate (bps)	Max D8PSK Data Rate (bps)
CENELEC A (36kHz to 91kHz)	4,500	14,640	29,285	43,928	46,044
FCC (150kHz to 487.5kHz)	21,000	62,287	124,575	186,863	234,321
FCC (10kHz to 487.5kHz)	38,000	75,152	150,304	225,457	298,224



US Power line Topology

Communication over MV lines and crossing MV-LV transformers is essential to building an efficient and cost effective remote meter management network

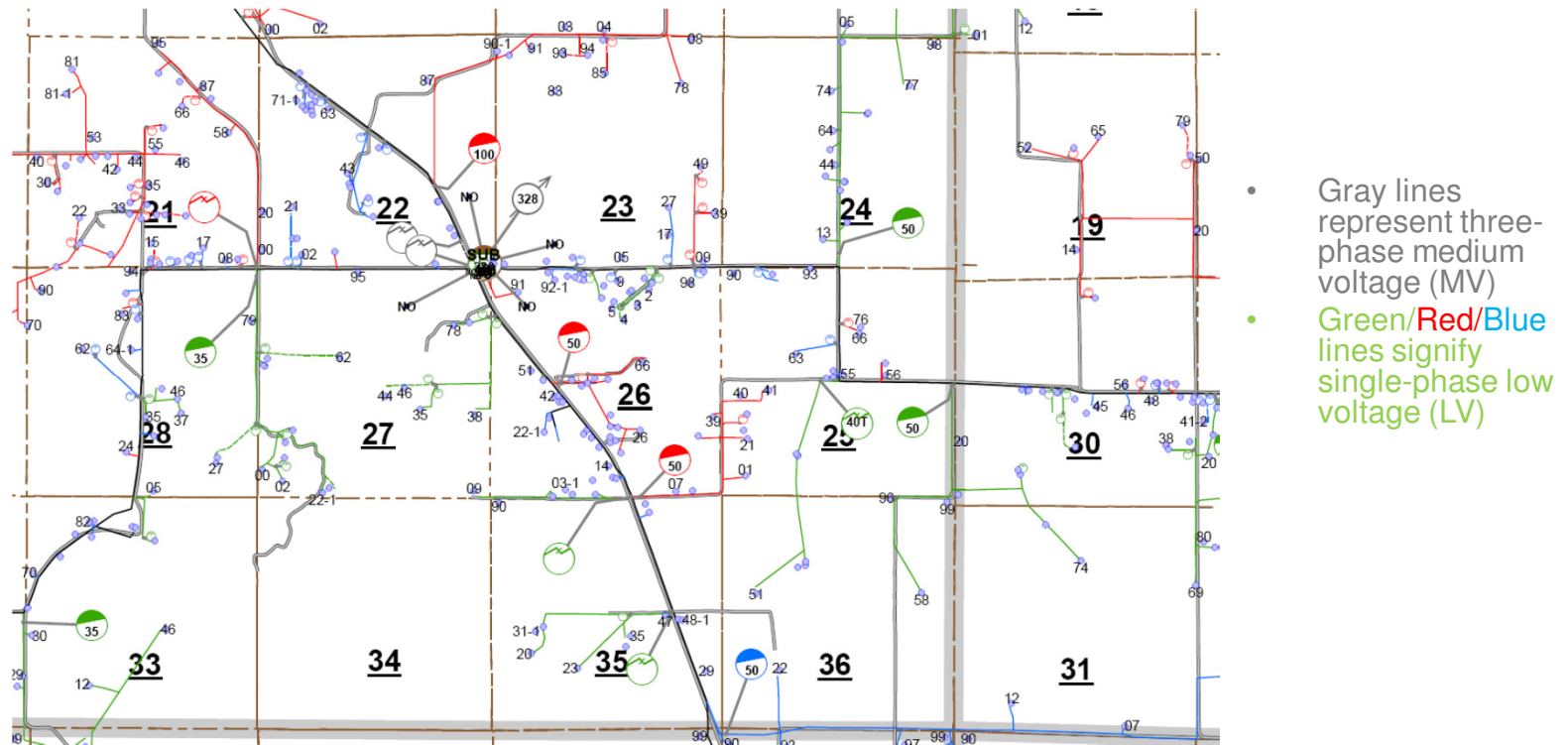

Power line distribution network in US is mainly done through MV lines

US Electricity Network Topology:

- Typically each MV -LV transformer provide power to 2 to 8 households in urban areas
- Typically each MV -LV transformer provides power to 1 to 2 households in rural area



Acceptance

- OFDM based narrow band PLC solution has been proven to be the most reliable mean of communication in AC line
 - Field results report from G3-PLC and Prime
- OFDM Based narrow band PLC are being accepted by utilities companies around the world
- Increase investment by semiconductor companies and system integrator.
- Multiple standardization such as ITU and IEEE are moving ahead to complete narrow band PLC specification.

Smart Grid and automatic meter reading infrastructure

Ability to broadcast messages in high peak demand situations

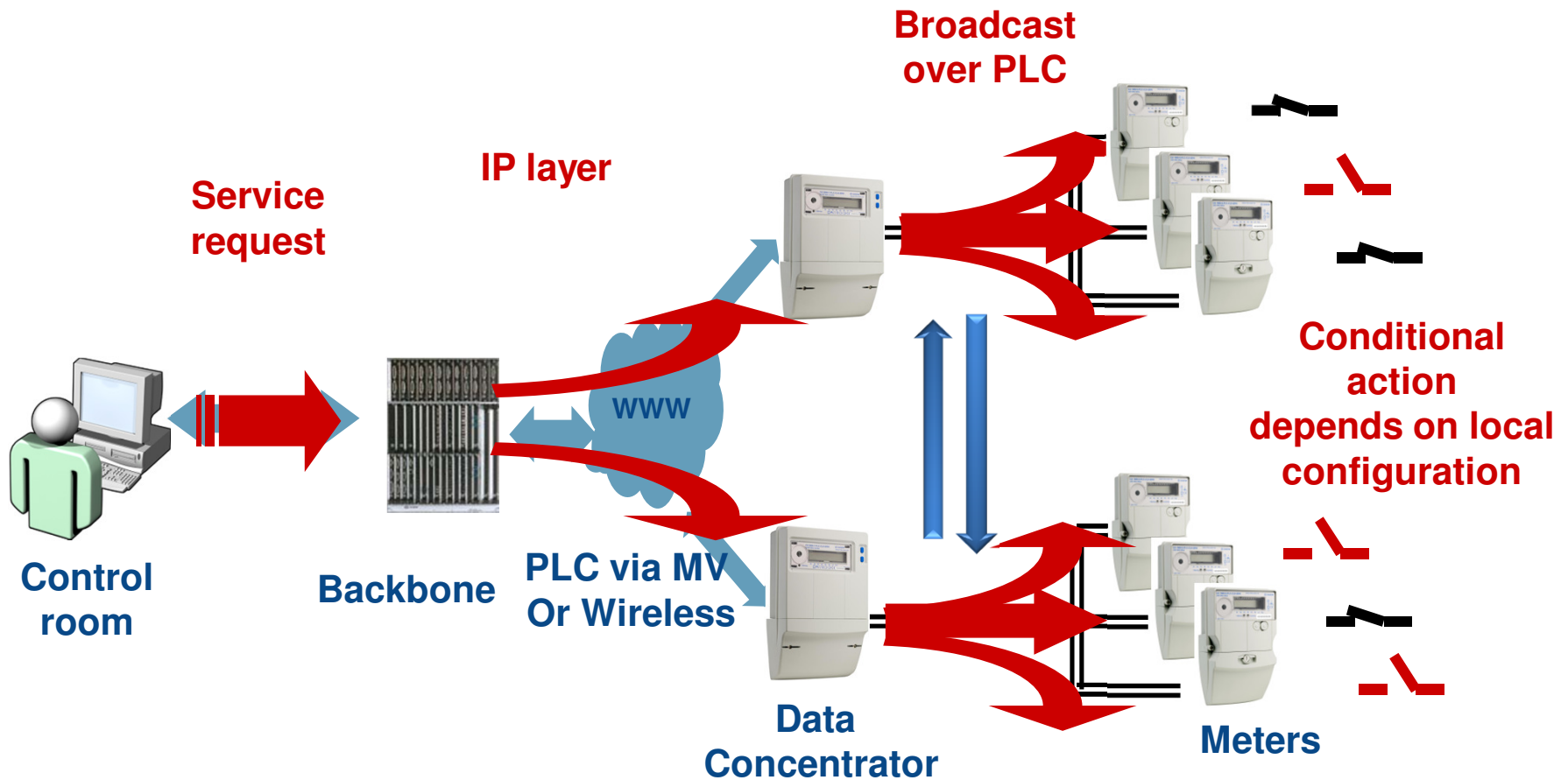



Smart Grid requirement

- Meter Reading (AMR)
 - Meter reading : Index and load profile

- Meter Management (AMM)
 - Meter reading : Index and load profile
 - Meter configuration: Tariff and contract change
 - Meter activation / de activation
 - Prepayment

- Smart Grid
 - Peak Load Management and Demand Side Management
 - Customer load control
 - Load Management
 - Energy loss measurement
 - Over load and phase balancing
 - Micro production control
 - Outage management
 - Early information and recovery control
 - Voltage and Quality measurements
 - Line loss detections



Requirements and Issues

- IP layer is used for Network Management to transport data and energy management in which categorize information into a coherent structure for analysis.
- Communication, Authentication and Routing are main elements on LV side.



Four Node Plus Peripheral Nodes

HOP 0 – Routing from A to B

- “A” needs to have a route to “B”
- “A” broadcasts a “Route Request Message” asking for a route to “B”

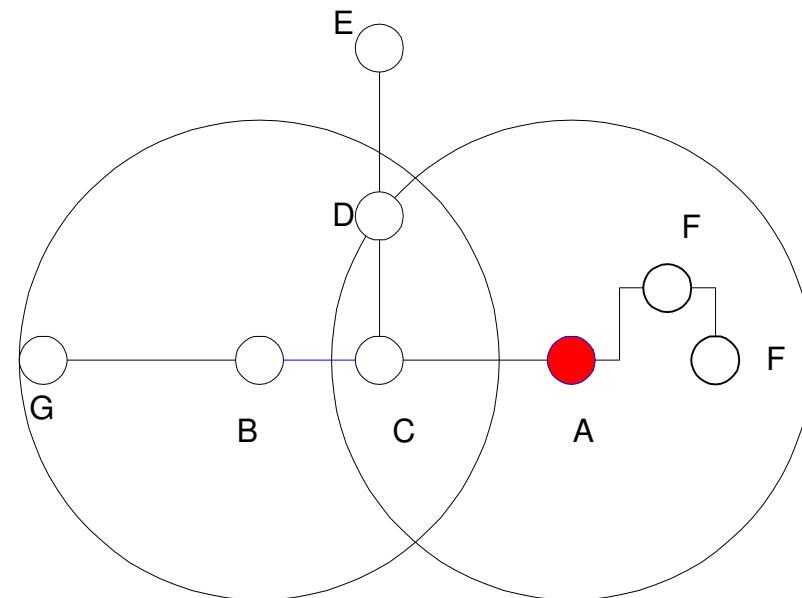

- Nodes “E”, “F”, and “G” are peripheral nodes that have nothing to do with the desired route generation, but react to the routing process

~LOAD~ Four Node Plus Peripheral Nodes

HOP 1 – Routing from A to B

- The **RED** nodes have received the “Route Request Message”
 - They store the address of “A” in their “routing table” at the address of “A”
 - They store the “Route Cost” of the path to “A” in their “Route Request Table”
 - They rebroadcast the “Route Request Message” with their “Route Cost” to “A”
- Node “D” has a higher “Route Cost” than Node “C”

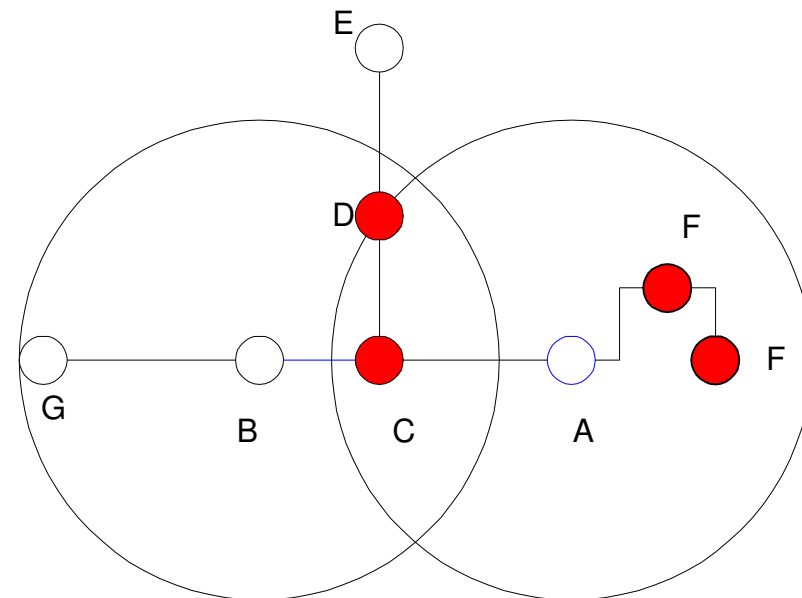

- The “F” nodes broadcasts of the “Route Request Message” wastes time on the Power Line



Four Node Plus Peripheral Nodes

HOP 2 – Routing from A to B

- The **RED** nodes have received the “Route Request Message”
- “E” updates its tables and rebroadcasts the Route Request message”
- “B” receives “Route Request Messages” from “C” and “D”
 - “B” must wait for all expected “Route Request Messages”
 - “C” is “B”’s address used for the Path to “A” because the “Route Cost” to “A” using “C” is lower than using “D”

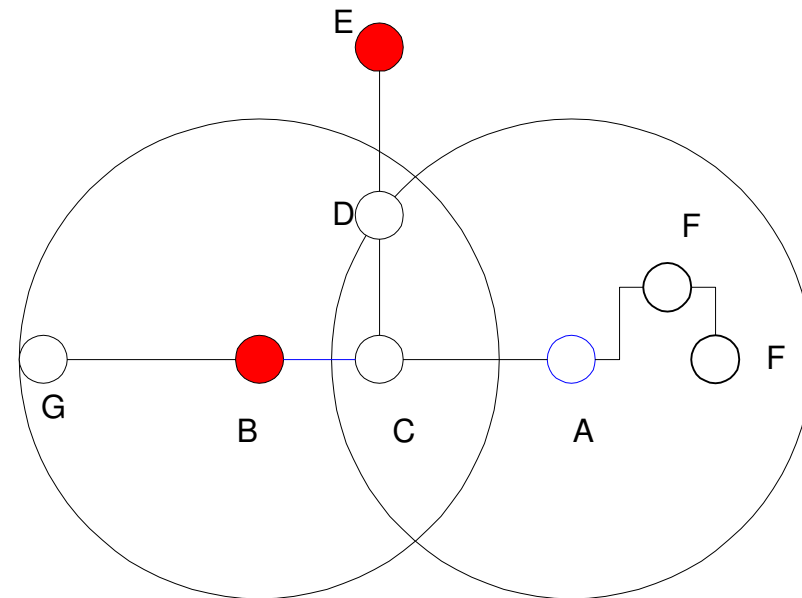

- Note: Node “G” never sees a “Route Request Message” because “B” doesn’t retransmit the message

~LOAD~ Four Node Plus Peripheral Nodes

HOP 4 – Routing from A to B

- "A" Evaluates the "Route Reply Messages"
 - In this case the path "A" to "C" to "B" is the only choice
- Note:
 - If "C" and "D" had the same "Route Cost" from "A", both would have returned Replies. Then "A" would chose the route with the best route to "A"

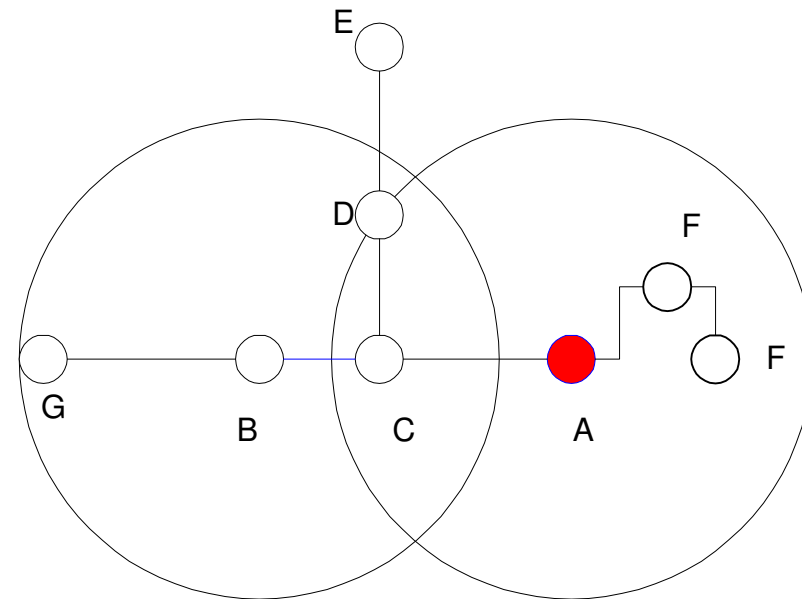



Routing Requirements

- Optimized routing maximized the use of channel
- Reduce collusion
- Flow control within routing nodes
- Evaluation of using the routing engine in Layer 2 or at layer 3.



MV Coupler Further work

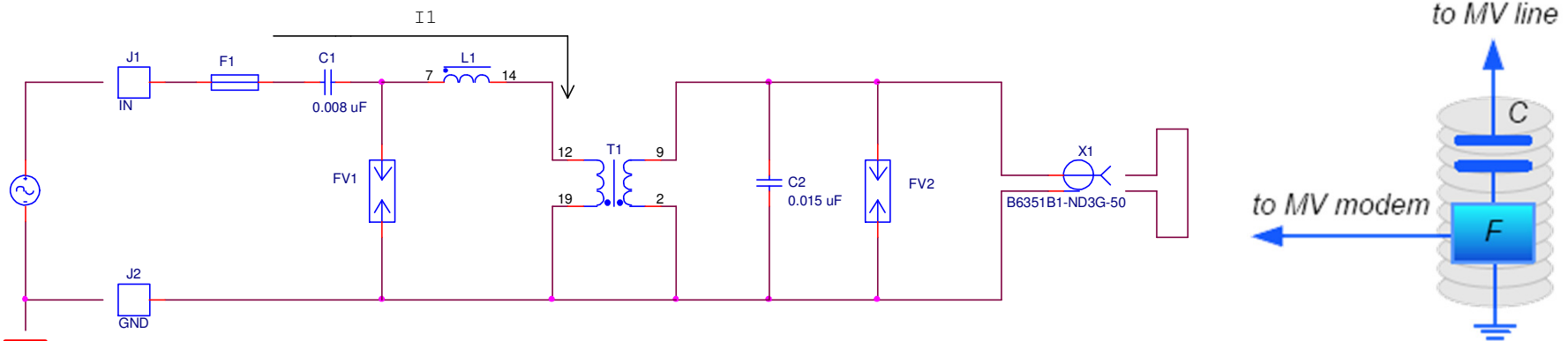

- Capacitive coupling unit (CCU) consists of a coupling capacitor and filters designed to operate in the Cenelec band

Primary rated voltage	24/ $\sqrt{3}$ kVRMS
Carrier frequency working range	35–500 KHz
Composite loss	~2 db
Nominal equipment -side impedance	75 Ohm
Rated lightning impulse voltage	125 kv
Partial discharge level	≥ 20 pC
Ambient temperature during Operati	-40° to +65°

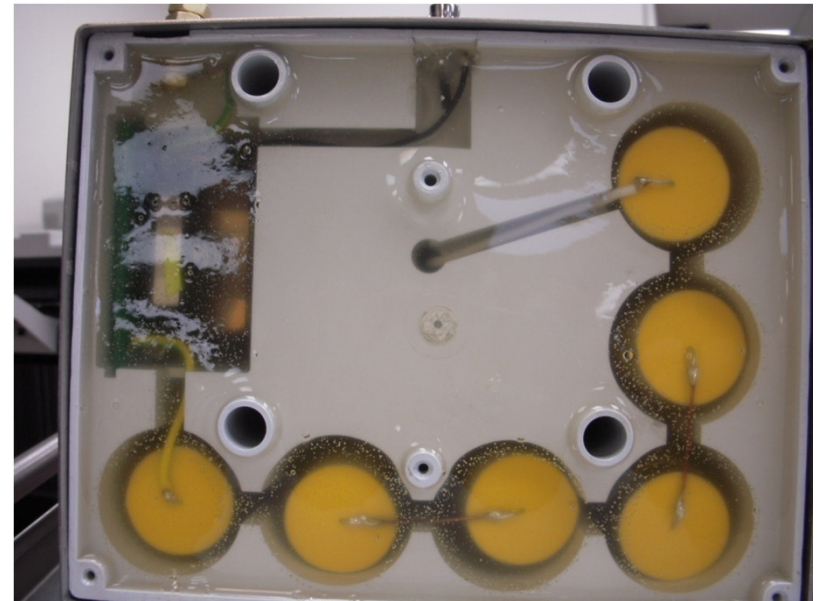



Automotive

- There are two approaches are being considered
 - PLC over Pilot line
 - PLC over AC main

Communication concept

- **PLC is top contender for EV-to Charger**

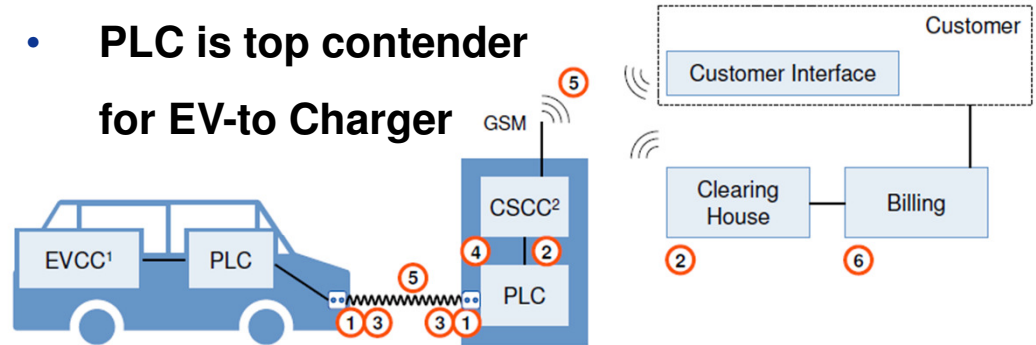

- ① Connection cable
- ② Contract authentication
- ③ Locking plug at EV and charge spot
- ④ Power on
- ⑤ Transferring of metering information
- ⑥ Billing of charge session

1) EV communication controller
2) Charge spot communication controller



Pilot Circuit with PLC Modem Test setup

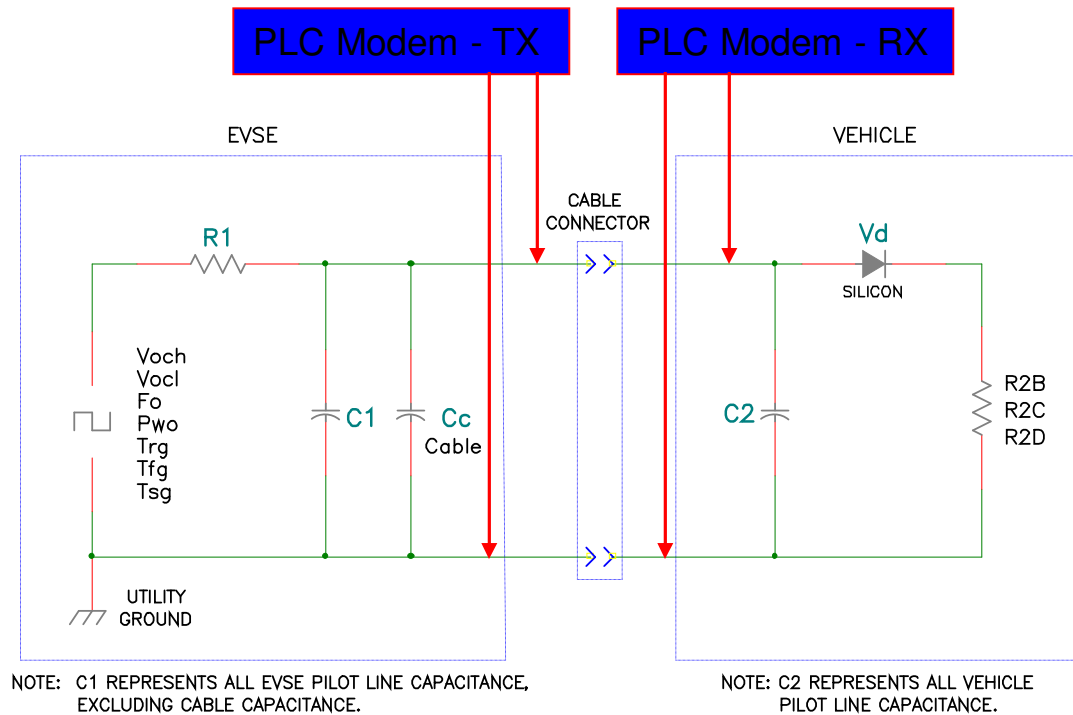

- Artificial Control pilot circuit from SAE J1772 standard Page-9.
- The cabling between EVSE and Vehicle is modeled in the circuit above.
- $C1 = 330\text{pF}$ $Cc = 27\text{pF}$; $R2 = 880\text{-}\Omega$; $C2 = 27\text{pF}$
- MAX2990 FCC modem with 390pF cap on transformer secondary is used for powerline communication



Modem Disconnected – 18Vpp Square wave with 20% Duty Cycle

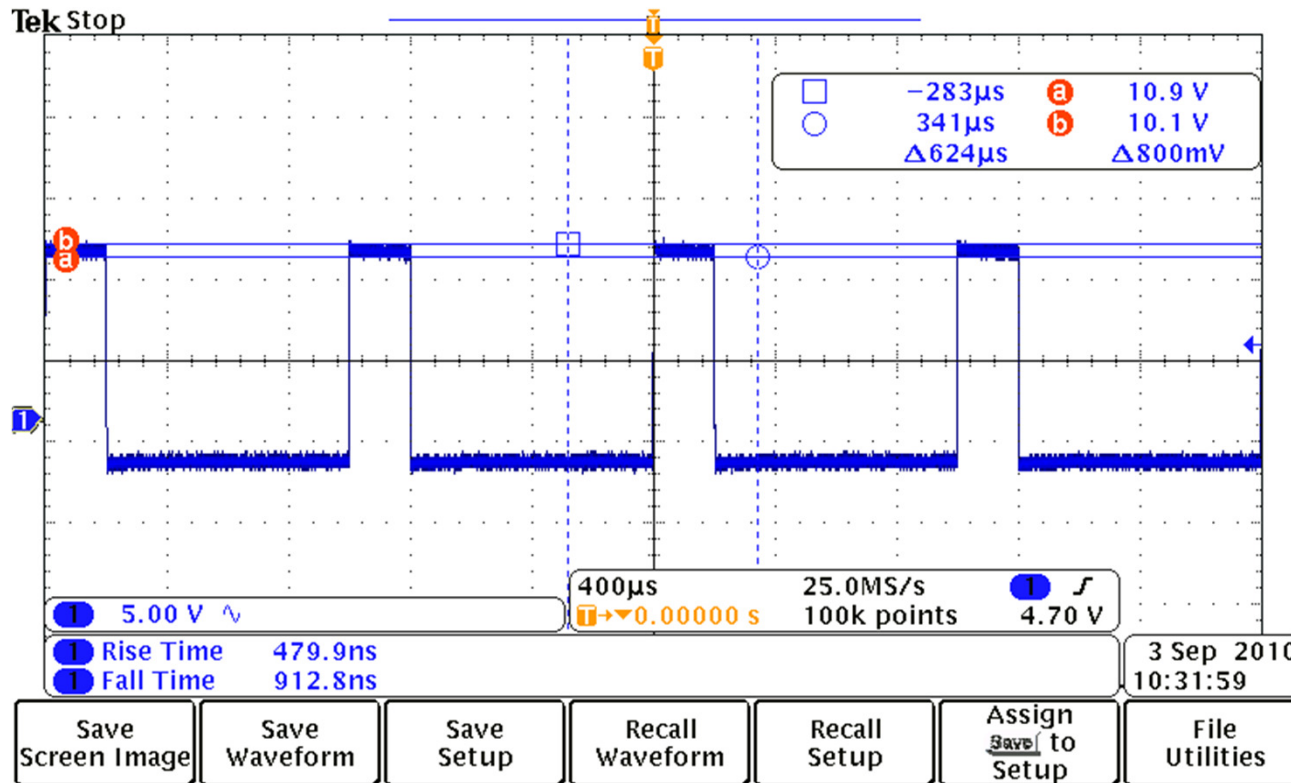

- In this test the PLC modems were disconnected to measure the pilot signal (1 KHz) rise and fall time.
- Rise Time = 0.479 usec
- Fall Time = 0.912 usec

Modem Connected, Communication ON – 18Vpp Square wave with 20% Duty Cycle

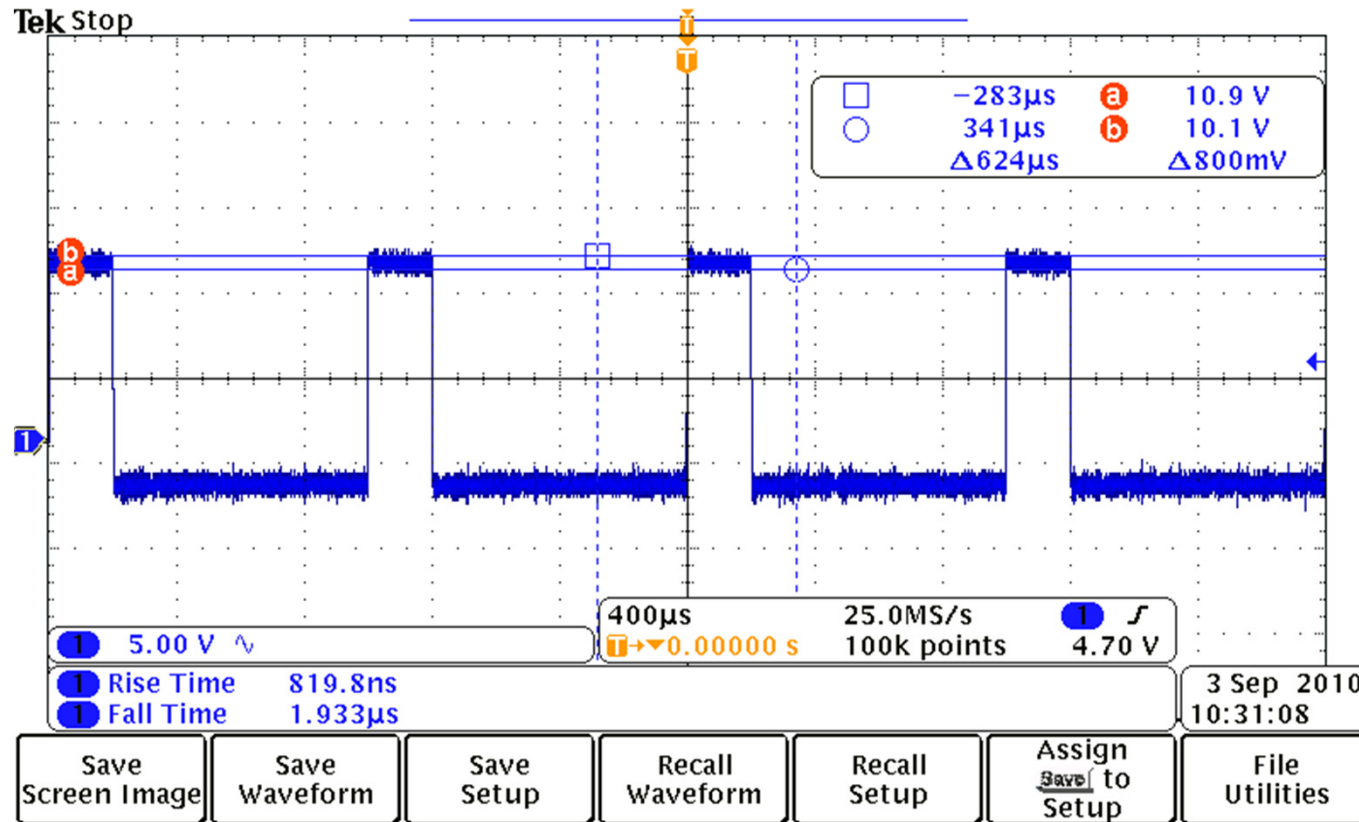

- In this test the PLC modems were connected and the communication was active during the pilot signal rise time measurement.
- Rise Time = 0.819µsec; Fall Time = 1.933µsec
- The rise and fall time with PLC communication active is less than 2µsec.
- Data Rate = 42-54Kbps.



Modem Disconnected – 12Vpp Square wave with 50% Duty Cycle

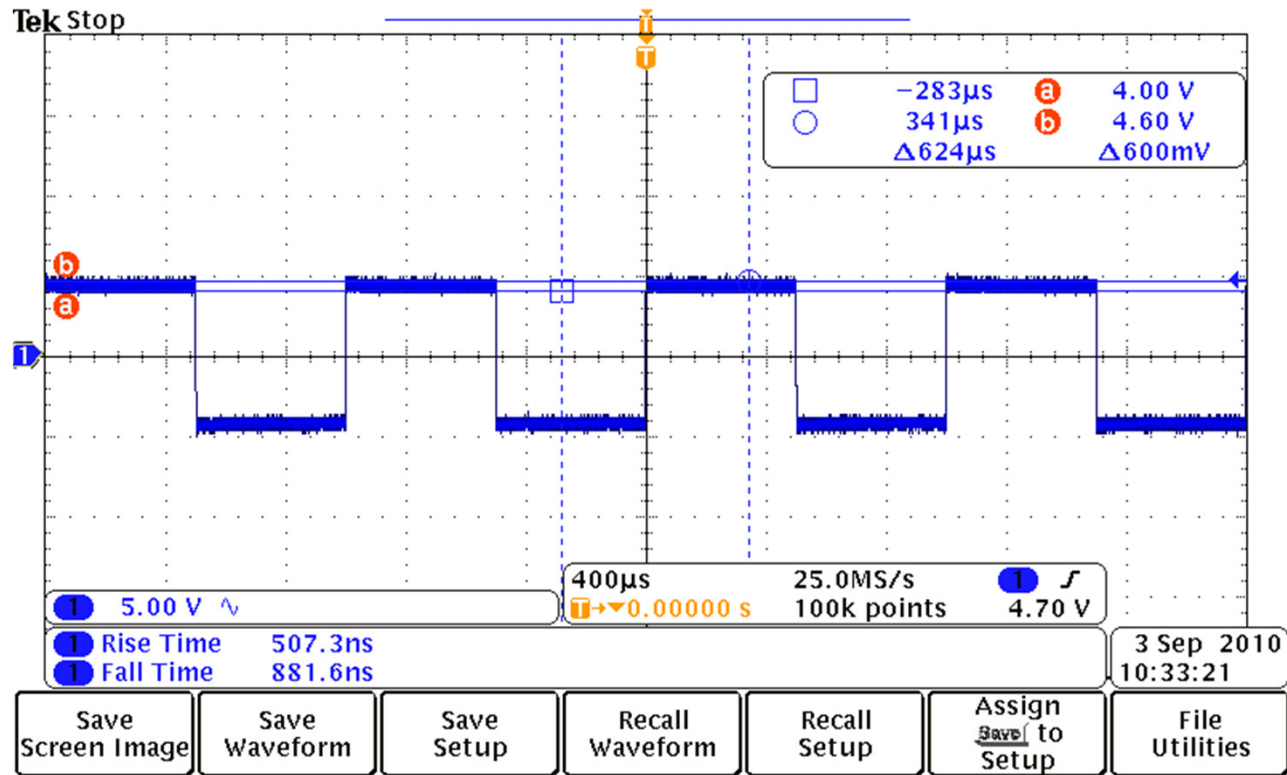

- In this test the PLC modems were disconnected to measure the pilot signal rise and fall time.
- Rise Time = 0.507 usec
- Fall Time = 0.881 usec

Modem Connected, Communication ON – 12Vpp Square wave with 50% Duty Cycle

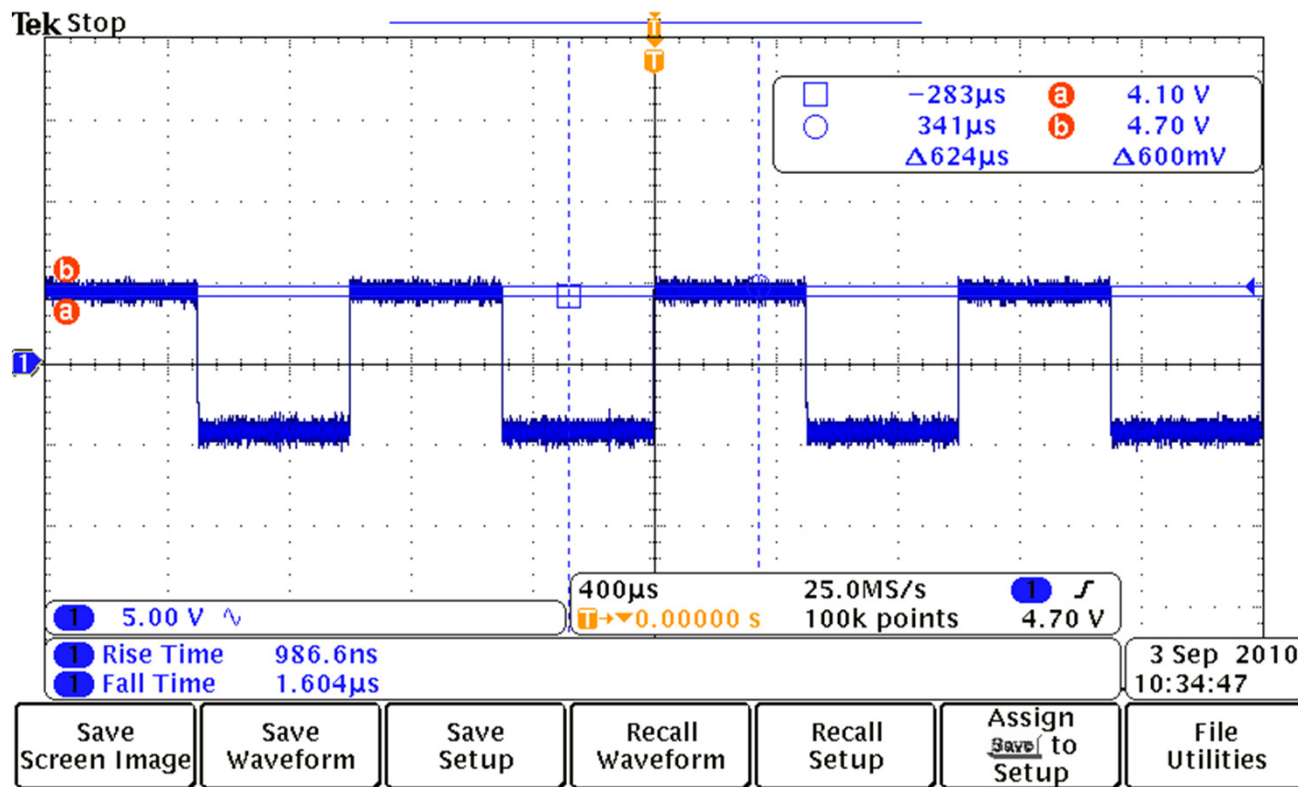

- In this test the PLC modems were connected and the communication was active during the pilot signal rise time measurement.
- Rise Time = 0.986usec; Fall Time = 1.604usec
- The rise and fall time with PLC communication active is less than 2usec.
- Data Rate = 62-74Kbps

Communication Test between EVSE and EV with onboard charger

- There is ~15dB more attenuation on high frequencies

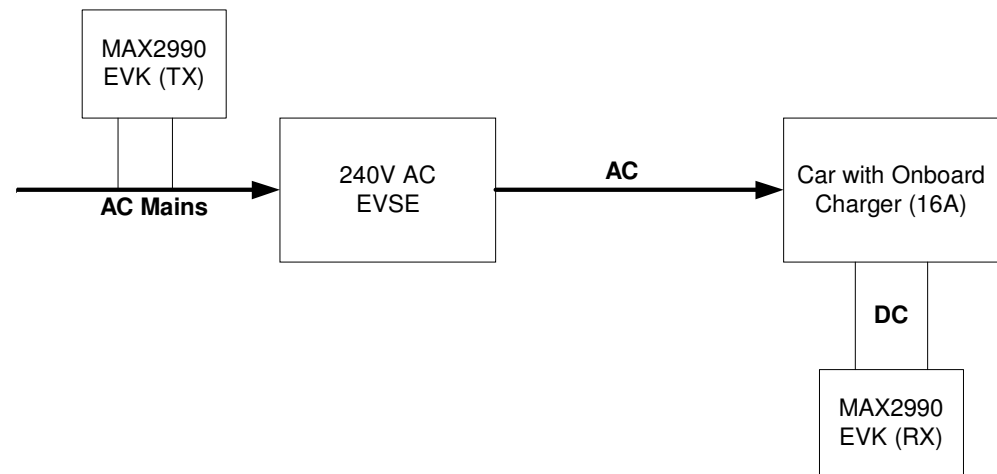
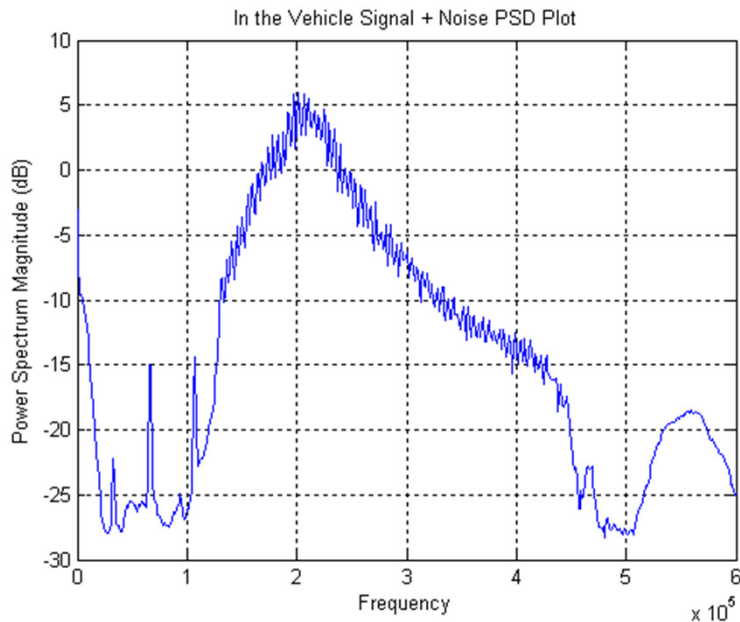



EVSE Contactor Test

- Narrowband PLC provide low conducting emission and contactor provides good isolation between TX and RX PLC

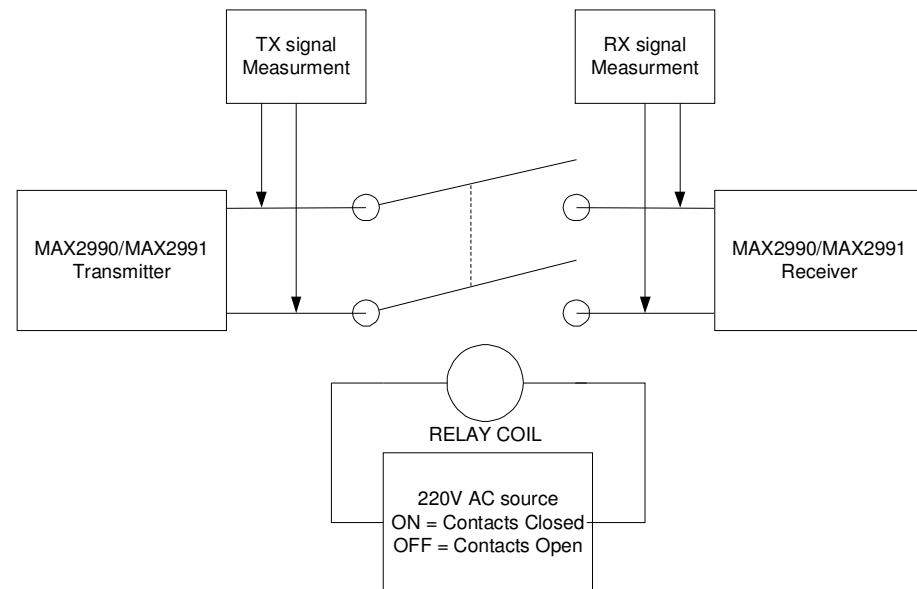
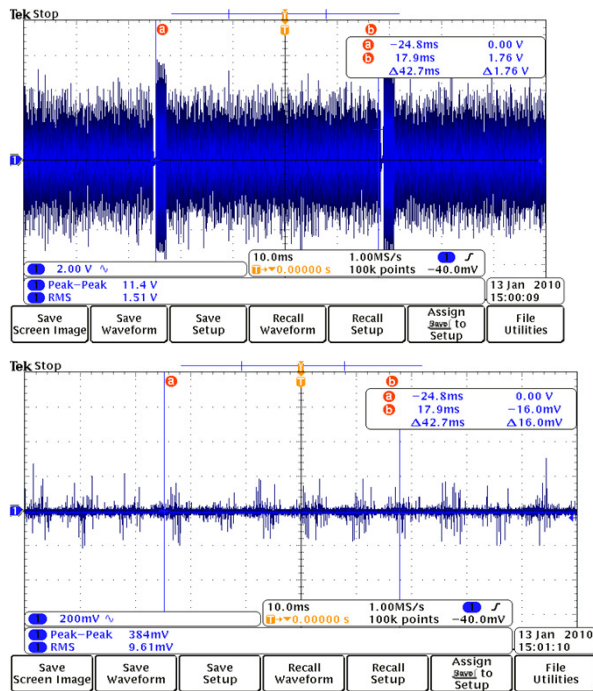

Communication Test between 100A DC EVSE and Battery

- There are switching frequency harmonics in the received signal spectrum.

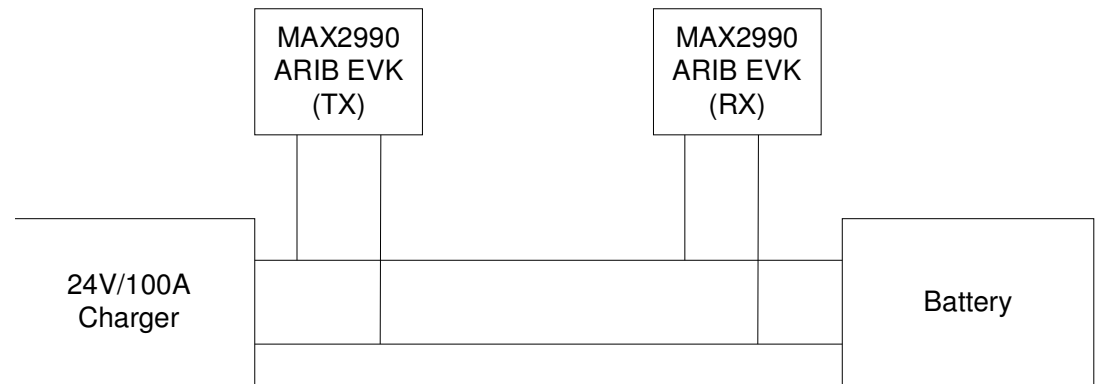
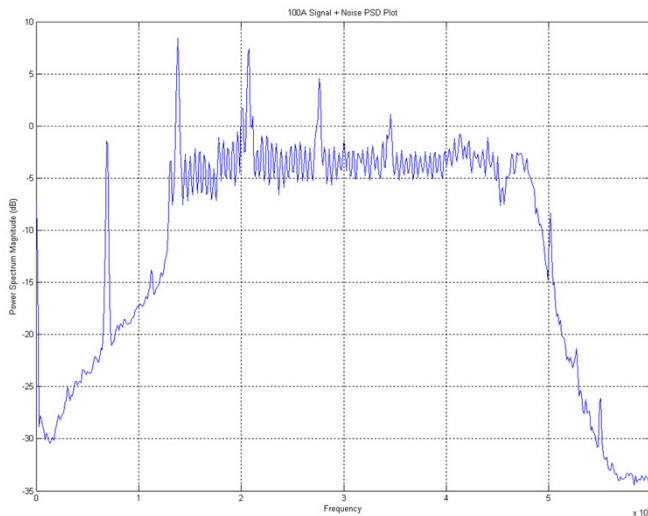

Communication Test between 250A DC EVSE and Battery

- There are 50 KHz switching frequency harmonics in the received signal spectrum. The harmonics are $\sim 20\text{dB}$ stronger than OFDM signal.

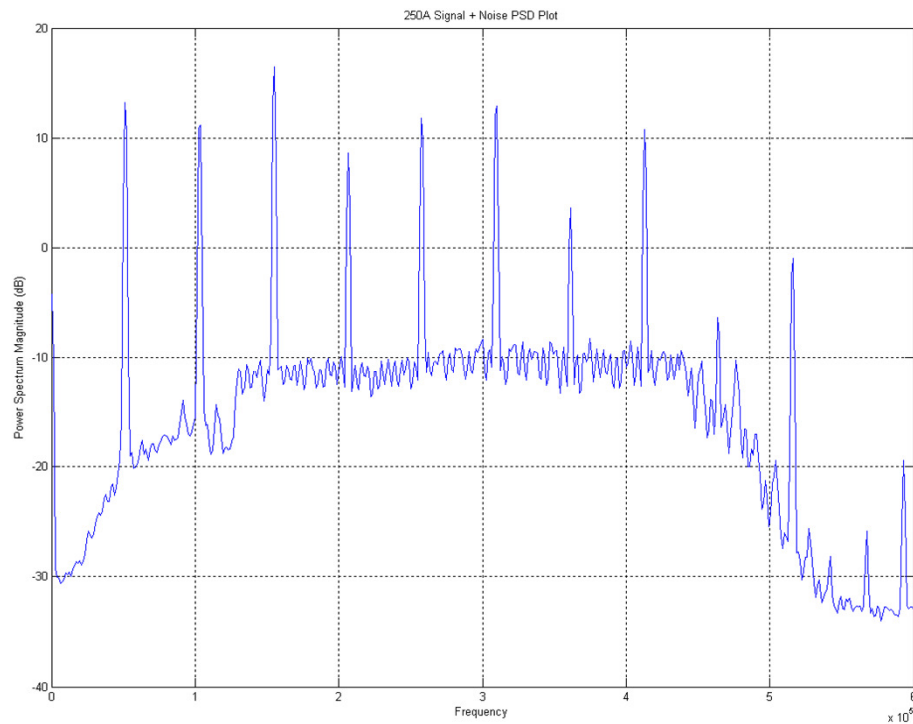

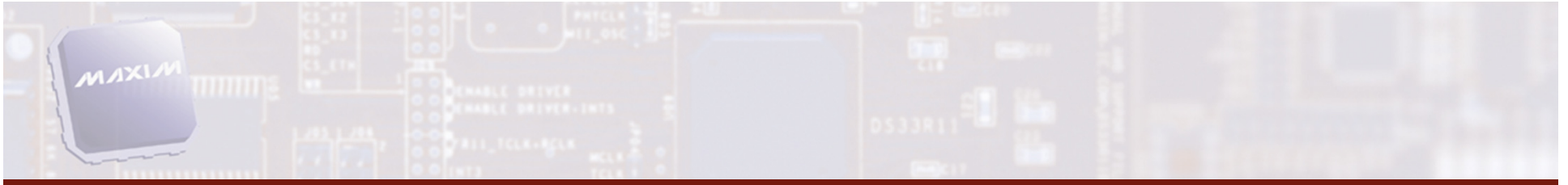

- Application requires a point to point communication.
- Channel receptive to switching power supply harmonics, low frequency PWM signal and it is frequency selective.
- It requires a PLC device with low conductive and emission interference.

PLC For Industrial Motor Control

Today a typical installation has about 3 lines
For insulation:
400V AC and 24V DC power line as well as
communication bus

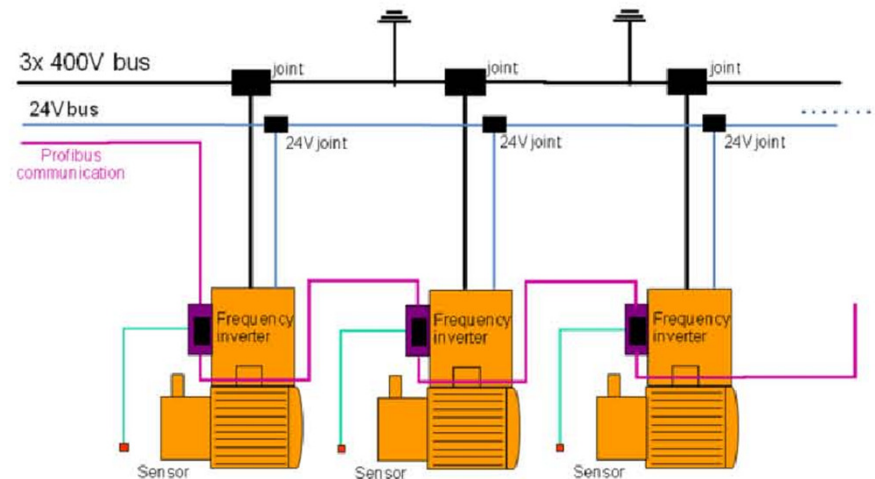

PLC communication is done via 400v AC Power Cable.

Advantages :

- Reduced number of components
- No additional wiring of bus lines necessary
- No risk of hidden failure in bus wiring
- Reduces installation and startup costs

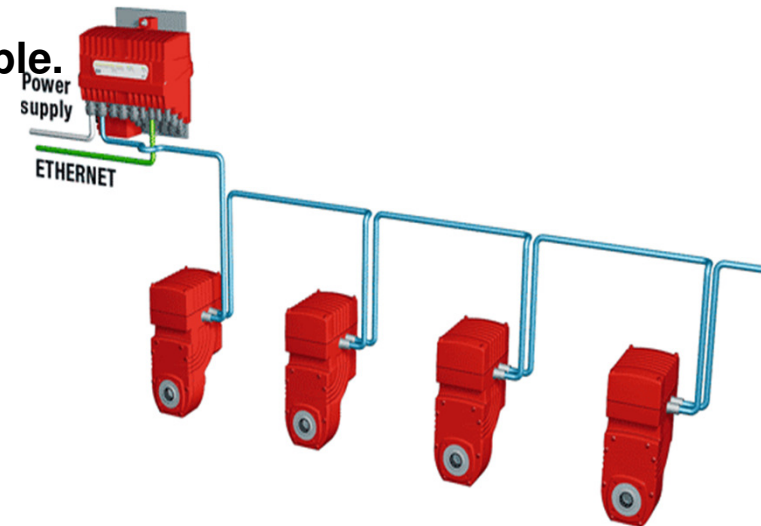



System Requirements

- Fast response time alerting anomaly. Response time varies per application from 30 to 1 ms.
- The ultimate response time for PLC should be lower than it requires for Programmer Logic Control.
- Data Packet size are small from few bytes to a maximum of 200 bytes
- Low cross talk interference
- Reliable communication
- Master and Slave topology

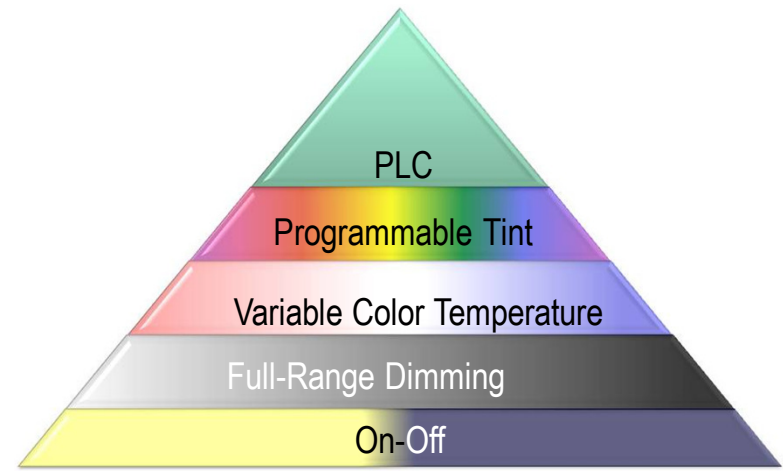

Fig. 1. Example of a Decentralized Installation Topology.



PLC in Lighting Applications

- New features and functions can be added to an LED luminaire using powerline communication technology
 - Enable dimming
 - Extended colors
 - Adjustable color temperature
 - Special effects
 - Savings on installation costs “no new wires”
 - Wider coverage than wireless
 - Transporting sensing information



- **With PLC LED luminaire can be positioned as a low cost, flexible, adaptive investment to end users**

- Application areas:

- Street lights
- Parking lots
- Airport lighting
- Building/General lighting
- Architectural lighting
- Outdoor billboards and displays





How dimming and coloring works in LED lighting

- LED's can be programmed to emulate dimming by splitting the time cycle into intervals of "On/Off".
- the LED receives the instructions from the PLC controller and changes the length of the "On " cycle time accordingly
- PLC Packet can carry RGB messages in multicast or broadcast format.
- Display moving picture by providing 30 message per second
- In some application PLC network can be isolated form the main AC line allowing to use unregulated frequencies.
- Point to point communication.

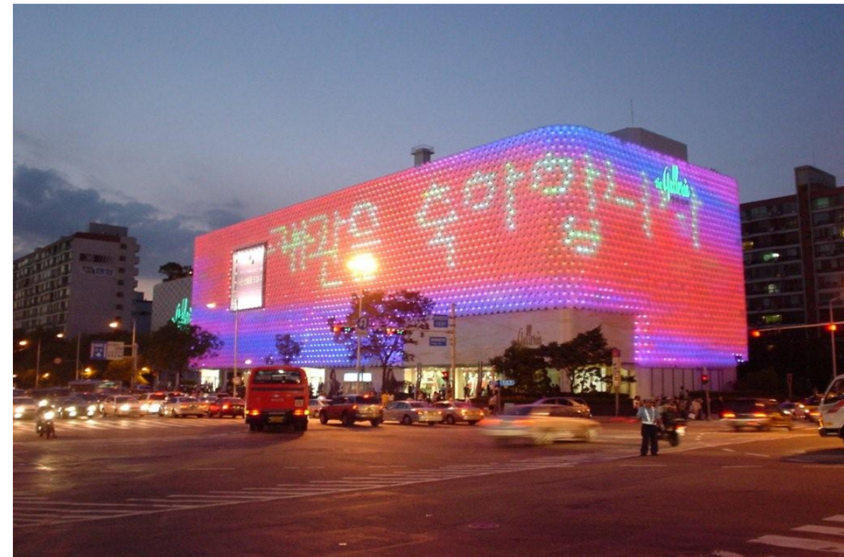
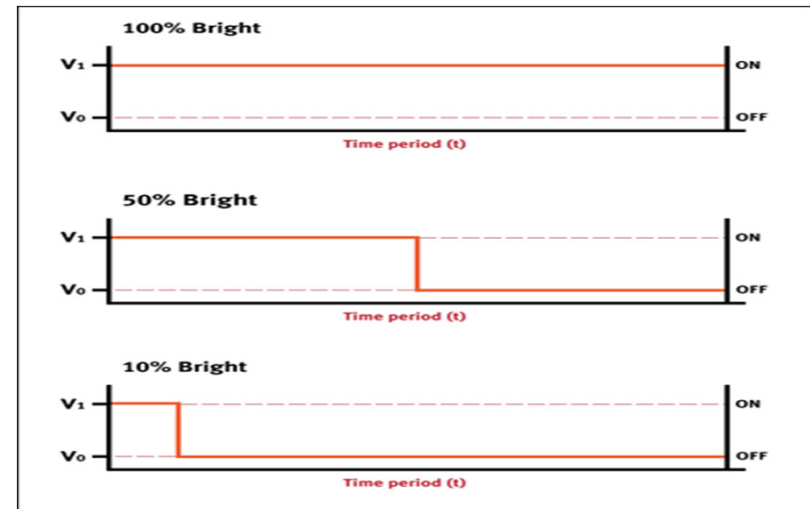



Powerline Communication Standardization

- Due to utility acceptances toward Power-Line communication and global push for smart grids, multiple standardizations actively working for defining a unified specification
- IEEE P1901.2 initiative addresses the specification of PLC both MAC and PHY between 9 to 500 Khz band.
 - 25 companies are participating.
 - G3-PLC Cenelec A and PRIM band are adapted
 - Currently working on Main body specification.
- ITU C.hmen initiative also addresses the specification of PLC both MAC and PHY between 9 to 500 Khz band.
 - G3-PLC Cenelec A, PRIM are adapted as Annexes
 - Currently working on Main body specification.
- Others
 - IEC/CENELEC
 - ISO/SAE



Conclusion

- With recent field test results and deployment, narrow band powerline communications (PLC) technology provides the required performance and cost efficiency for medium- and low-voltage power grids.
- As PLC narrow band is gaining market acceptance, new application areas are evolving such as automotive EV charging, lighting and industrial automation.
- PLC must overcome many new challenges to adapt to these new applications where university and research entities present and participation is essential for success.

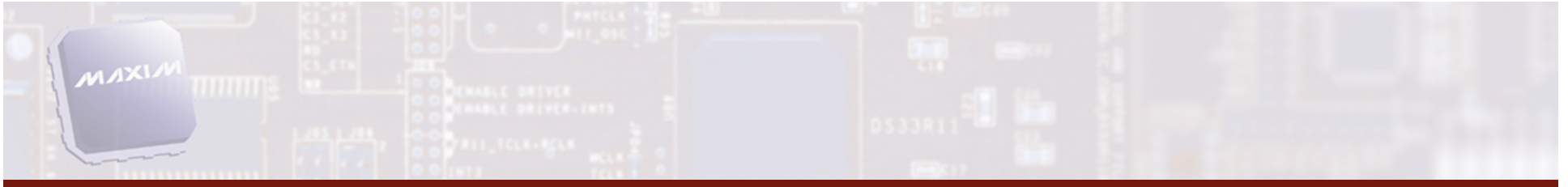

■ **Thank you for your attention**